

# Flow cytometry





**Sabzevar University**  
of  
**Medical Sciences**



# The principles and applications of flow cytometry

---

By

Dr. Saeideh Sadat Shobeiri

PhD of Immunology

# What Is Flow Cytometry?

- ✓ An instrument for making cell-based **fluorescent** measurements.
- ✓ Method for **quantitating** cellular or structural components of a cell using fluorescent antibodies or probes.
- ✓ Allows analysis of **Tens of thousands** of cells in minutes.
- ✓ A method to **sort** and collect specific cell types.



# What Is Flow Cytometry?

- ✓ **Flow** ~ Fluid
- ✓ **Cyto** ~ cell
- ✓ **Metry** ~ measurement
- ✓ Measuring properties of cells while in a fluid stream

# What Is Flow Cytometry?

- Flow Cytometry is a powerful technology for **characterizing** and **analyzing** particles of interest, such as cells, chromosomes, bacteria and beads.

# What Is Flow Cytometry?

## Sample Types

Cells

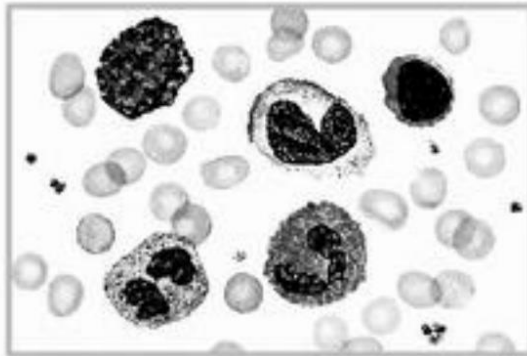

Chromosomes



Bacteria

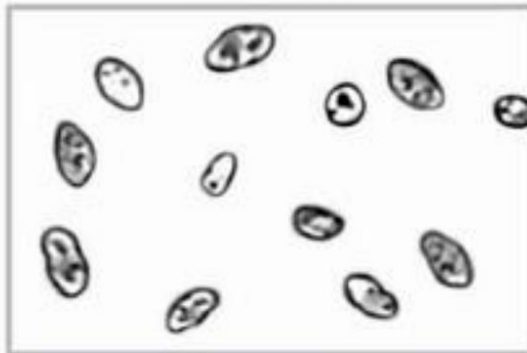

Beads

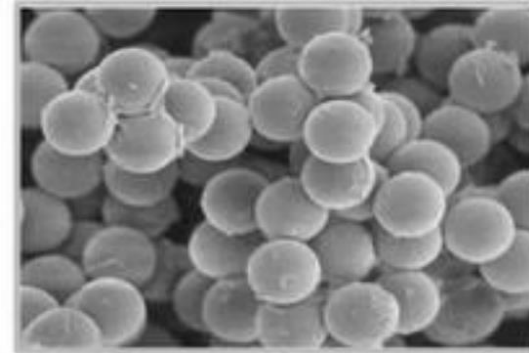

# Particle Size

- ❑ All cytometer samples must be in **liquid** suspension.
- ❑ Cells from solid tissue must be **disaggregated** before analysis.
- ❑ Typically particles or cells from **0.2** to **50** micrometers in size are suitable for flow cytometric analysis.



# Flow Cytometric Measurement

- A cell's or particle's relative size, internal complexity, and **fluorescence** intensity can be measured by flow cytometry.

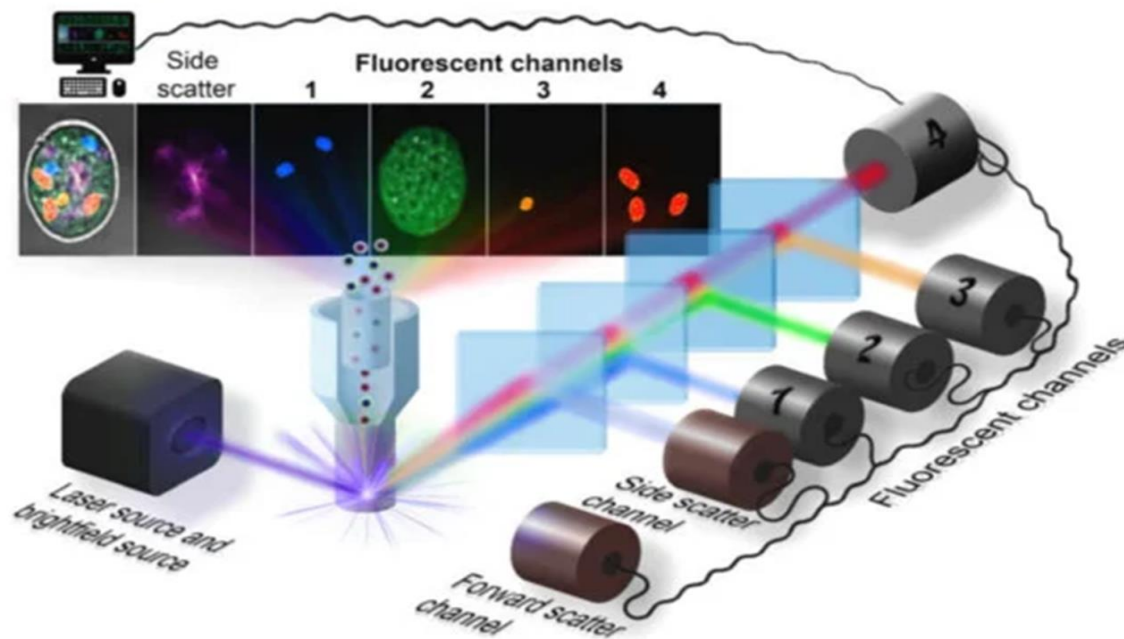

# Principles of the flow cytometer

- **Fluidics system**

- The fluidics system transports particles in a stream to the laser beam for interrogation.

- **Optics and detection**

- The optics system consists of lasers to illuminate the particles in the sample stream and optical filters to direct the resulting light signals to the appropriate detectors.

- **Signal processing**

- The electronics system converts the detected light signals into electronic signals that can be processed by the computer.

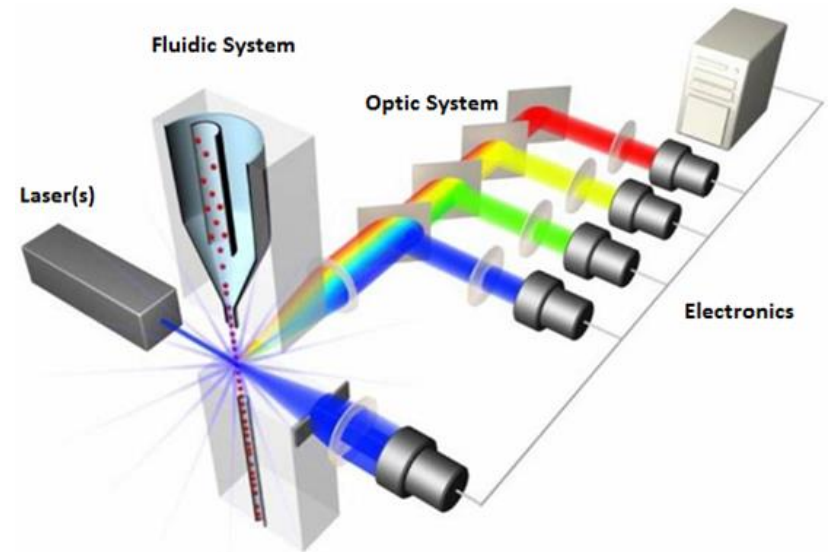

# Principles of the flow cytometer

## The Cytometer's Architecture

### What Flow Cytometer do?

Particles in suspension flow in a single-file (I) across an illuminated volume where they scatter light and emit fluorescence that is collected, filtered (II) and converted into digital values that are visualized and stored on a computer (III)

### What is a Sorter?

Allows the isolation of particles based on the above scatter and fluorescent properties (IV)

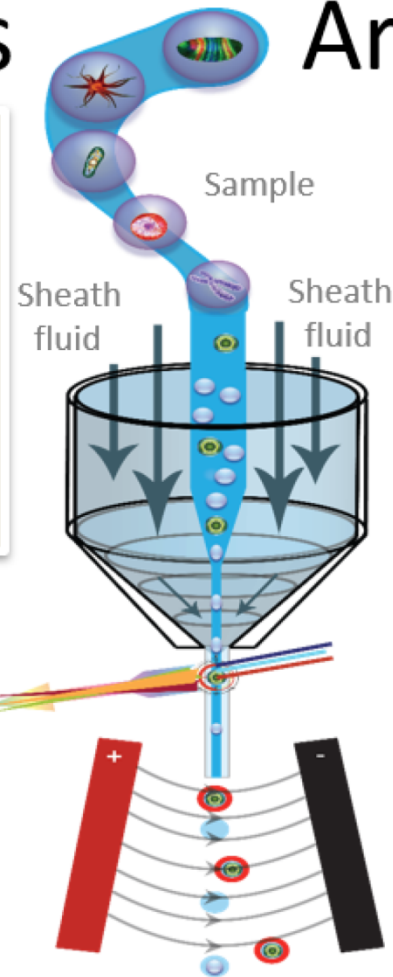

### Fluidics (I)

Flow chamber

hydrodynamic focusing

Focused lasers

### Optics (II)

Sorting (IV optional)

### Electronics and display

(III)

B

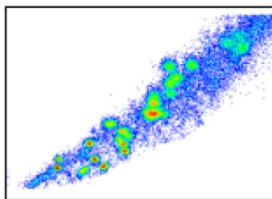

A

Fluorescence + Light Scatter



# Principles of the flow cytometer

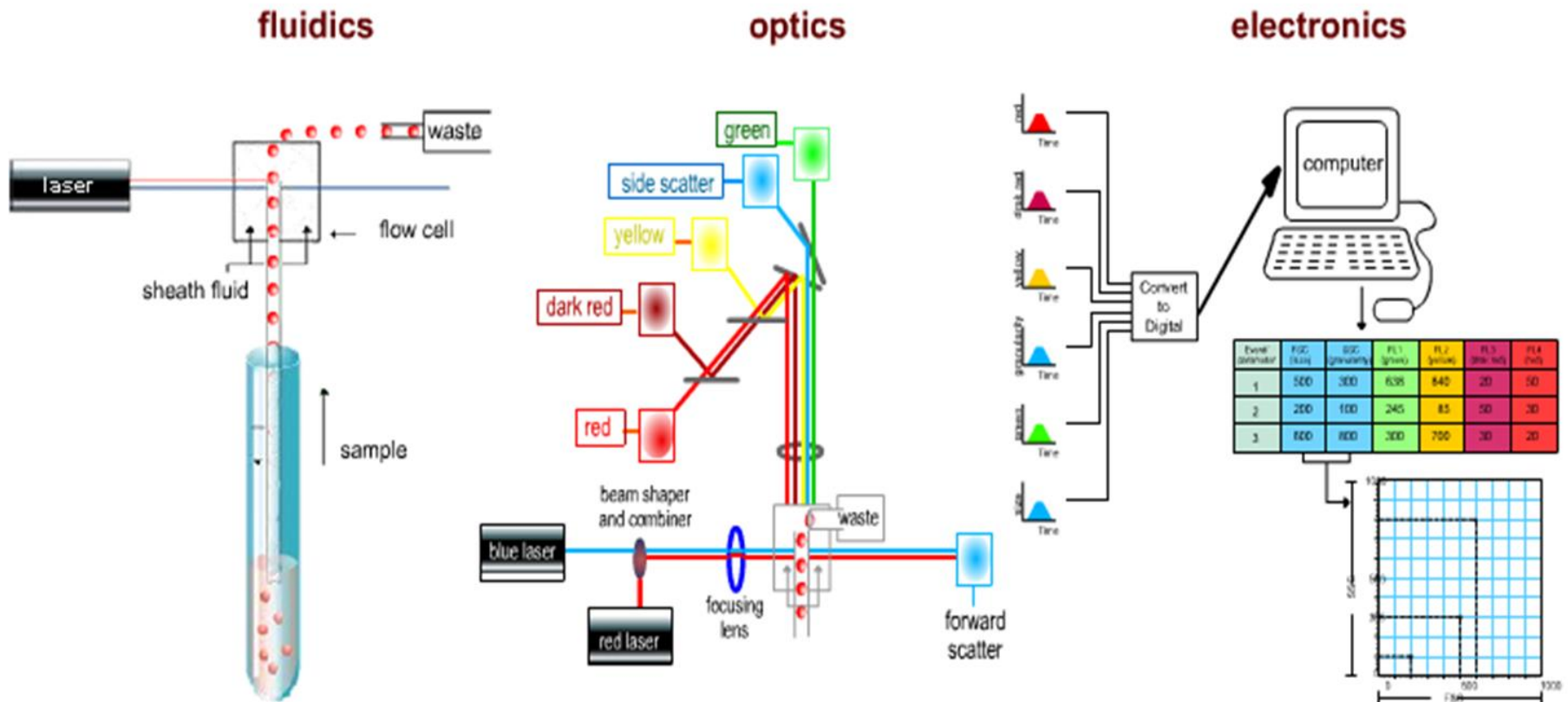

# Fluidic Subsystem

- ❑ The fluidic subsystem transports particles in a **fluidic stream** to the laser beam for interrogation.
- ❑ The portion of the fluid stream where particles are located is called the **sample core**.
- ❑ The point at which particles meet the laser beam is the **interrogation point**. Incident laser light is scattered and fluorescence is emitted as particles pass through the interrogation point.

# Fluidic Subsystem

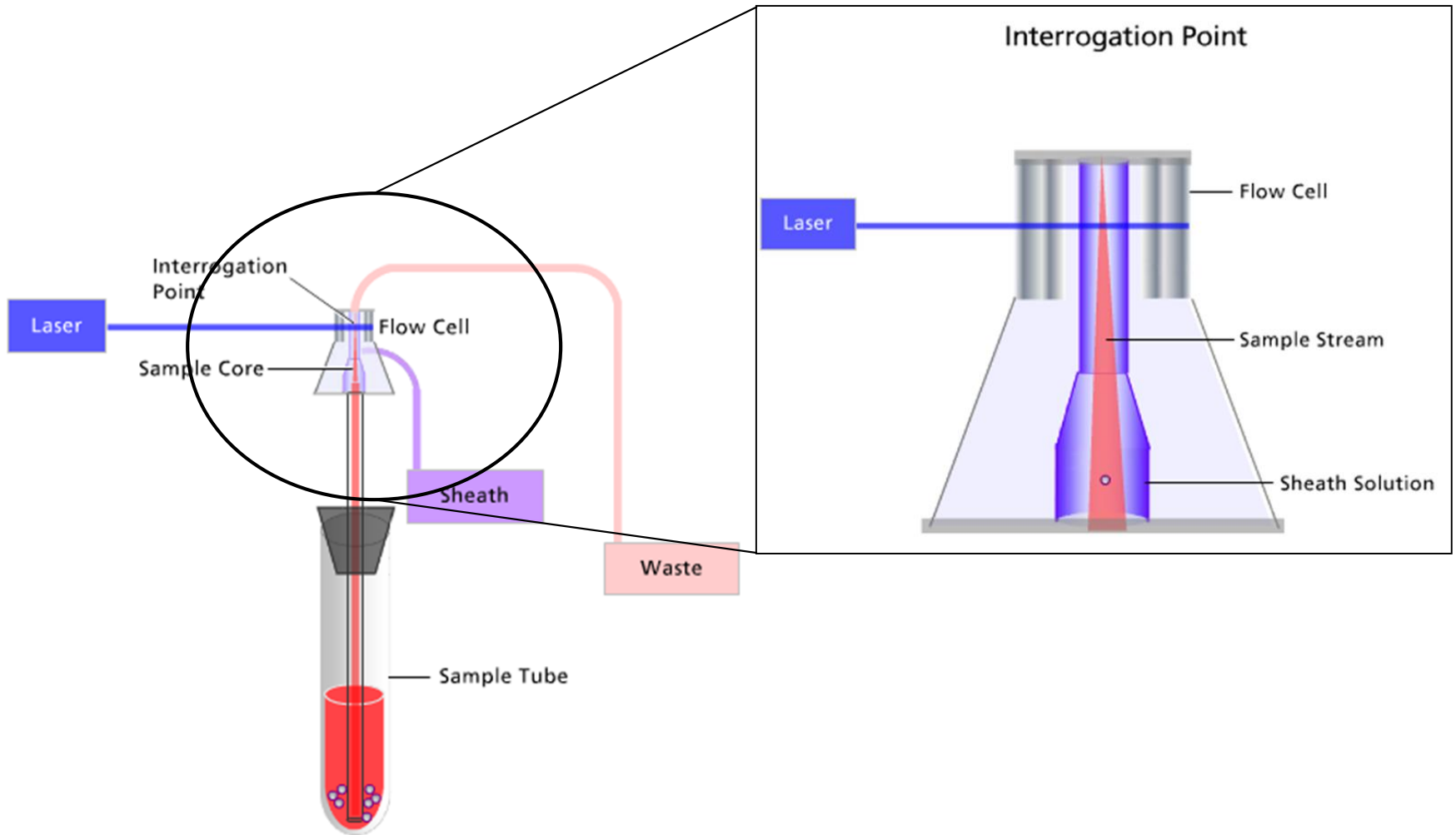

# Hydrodynamic focusing

- ❑ Hydrodynamic focusing positions the sample core in the **center** of the sheath fluid.
- ❑ The design of the flow cell allows hydrodynamic focusing to occur and provides the means for the cells or particles to pass through the laser beam **one at a time** for interrogation.

# Hydrodynamic focusing

- ❑ **Flow cell:** with the flow cell, both the sheath fluid and sample fluid meet. The shape of the flow cell enables hydrodynamic focusing.
- ❑ **Sheath Fluid:** the sheath fluid surrounds the sample core. The pressure of the sample fluid can be adjusted to increase or decrease the diameter of the sample core.
- ❑ **Sample Core:** as both the sample core and sheath fluid move through a narrowing channel in the flow cell, the sample core remains in the center of the sheath fluid without mixing. This process is called **hydrodynamic focusing**.

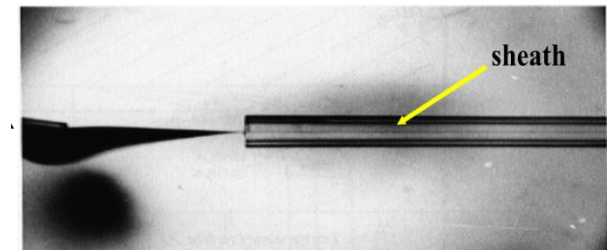
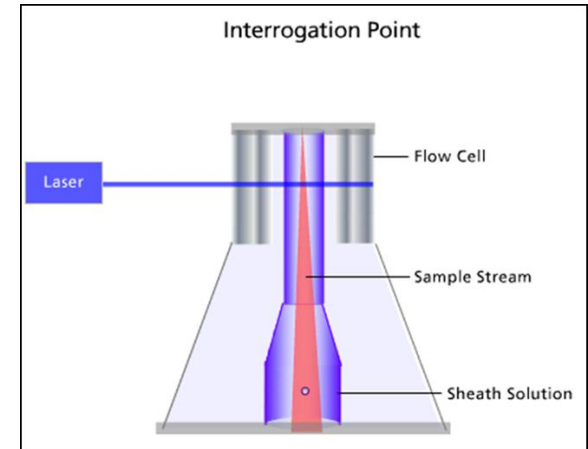

# Fluidic Subsystem

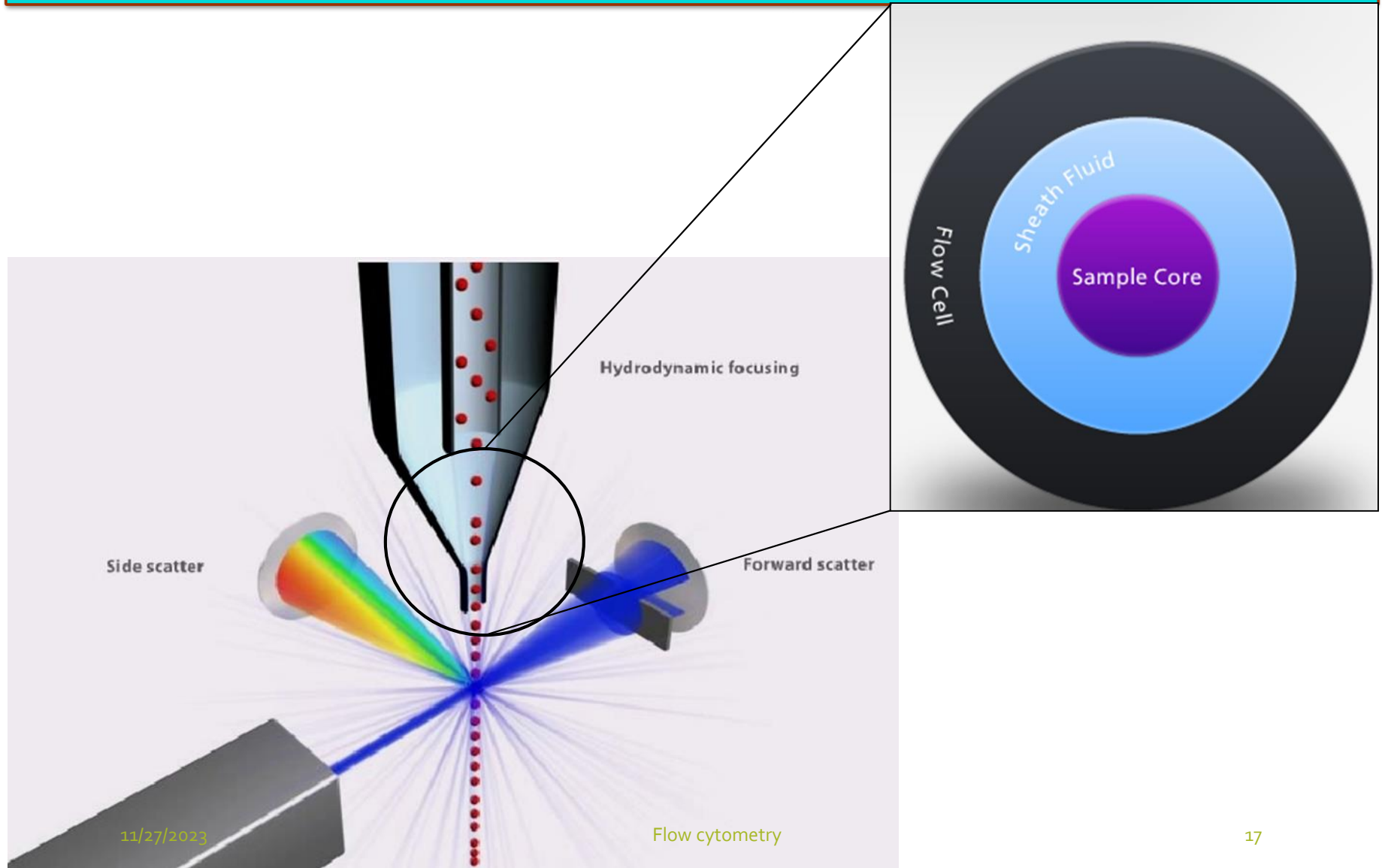

# Fluidic Subsystem

## Sample Pressure

- ❑ Difference in pressure between sample and sheath
- ✓ control sample volume flow rate
- ✓ The greater the differential, the wider the sample core.

Faster cell analysis BUT loss of resolution!!

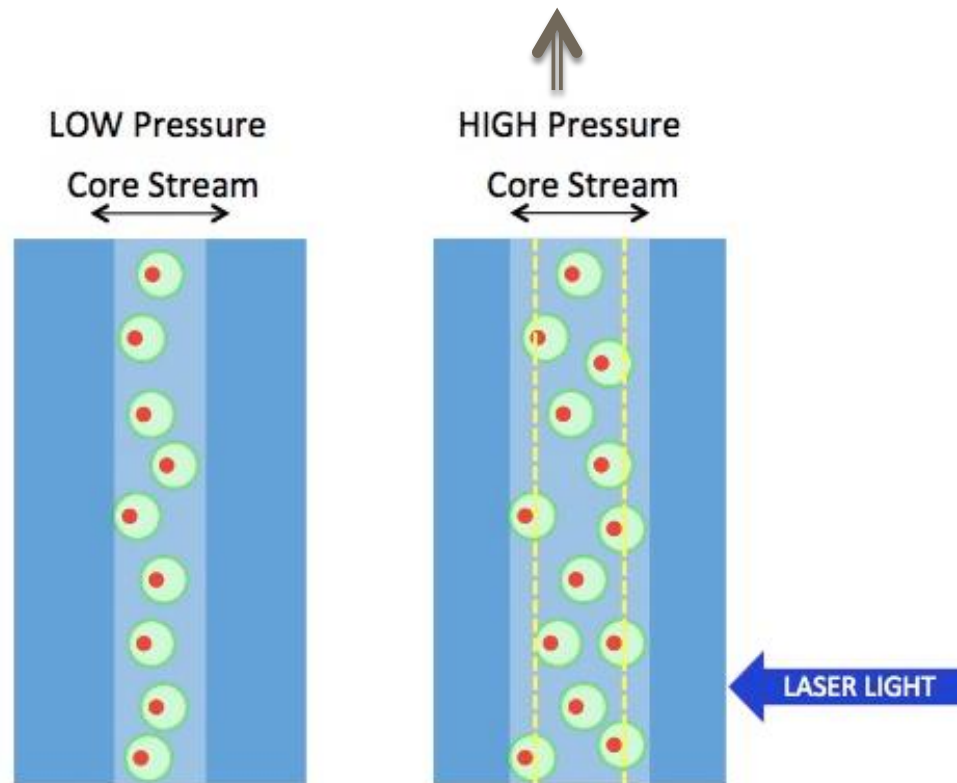

# Sample Pressure and Flow Rate

Flow rate is important from the time of sample preparation

Low sample pressure, low average cell count. This gives greater accuracy, but takes longer



Average Count  
240  
Events/sec

High sample pressure, high average cell count. This gives less accuracy, but is much faster



Average Count  
1200  
Events/sec

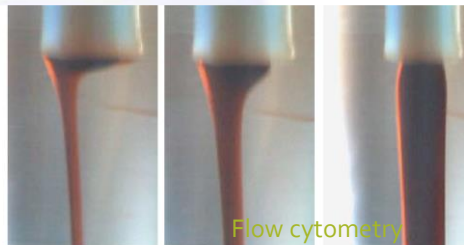

Flow cytometry

# Optic Subsystem

## Excitation Components

□ The optic subsystem consists of **excitation** and **collection** components.

□ The excitation components include lasers, beam shaping **prisms**, and lens to route the laser beams to the sample core.

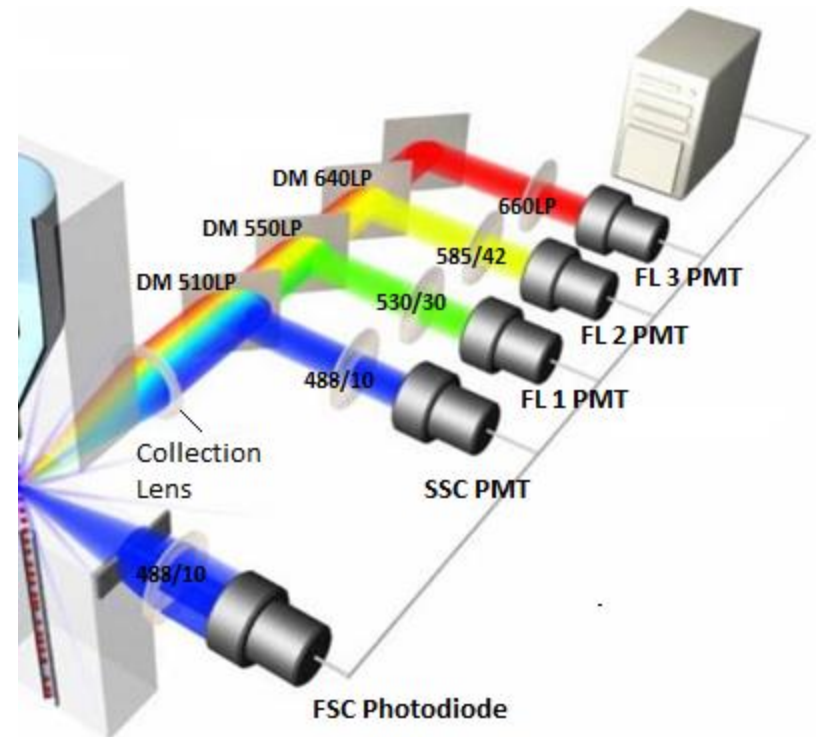

# Lasers in Cytometers

- ❑ **L**aser is an acronym for **L**ight **A**mplification by **S**timulated **E**mission of **R**adiation. Lasers generate intense beams of coherent light.
- ❑ In flow cytometers, lasers serve as the **excitation light source** for sample interrogation.

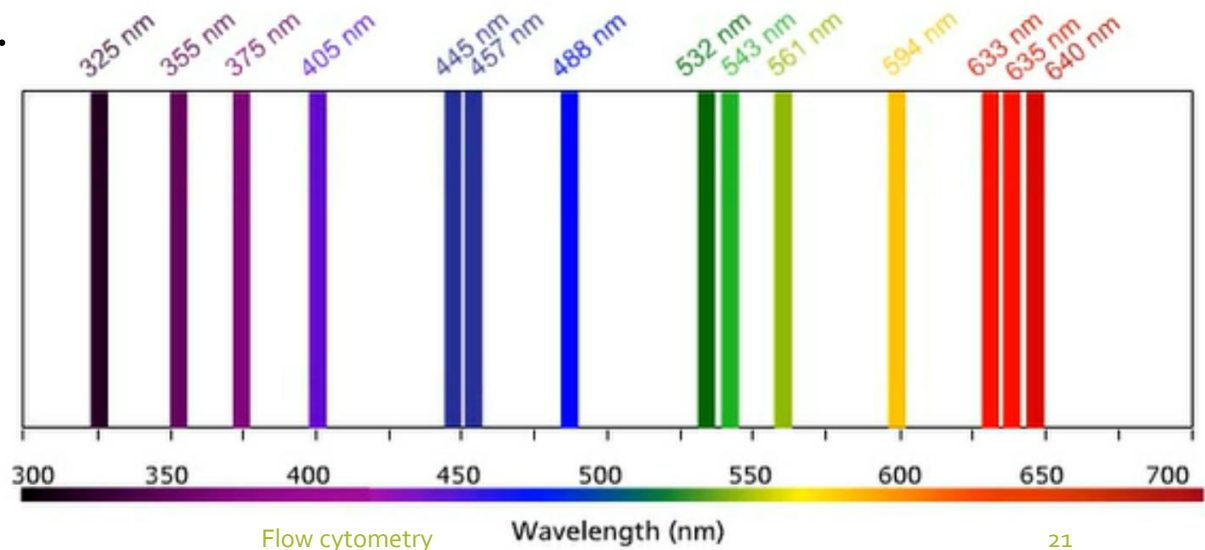

# Types of Light Scatter

□ **Forward Scatter** signal is detected just off the axis of the laser beam in the **forward** direction.

□ **Side Scatter** signal is collected at approximately **90 degrees** to the laser beam.

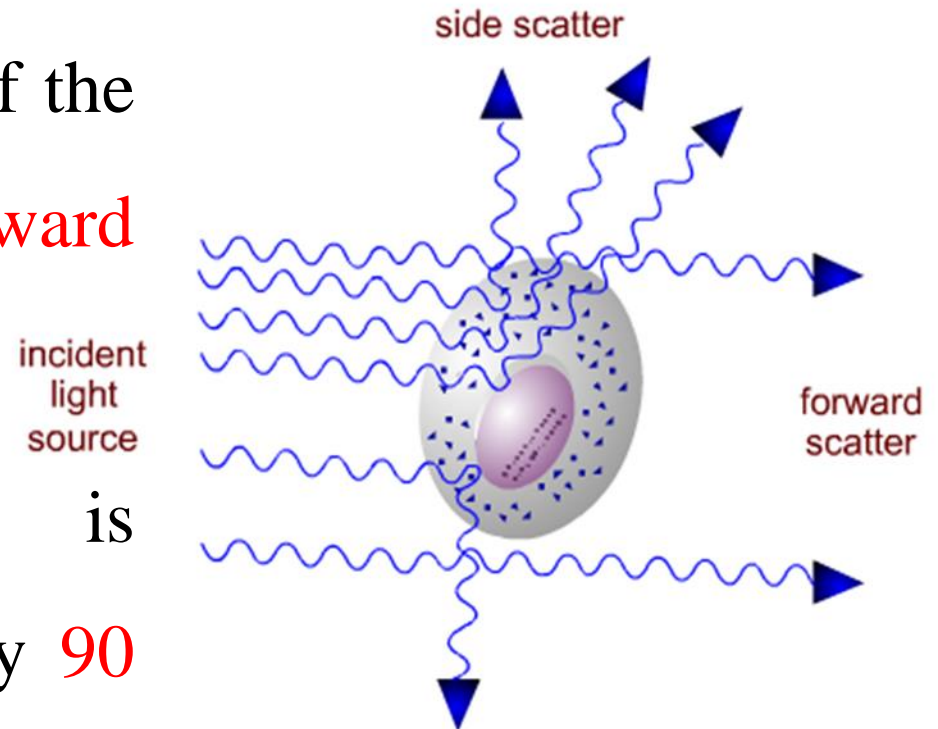

# Forward Scatter

- Forward Scatter light is based on two properties: **Size** and **Refractive Index (RI)**.

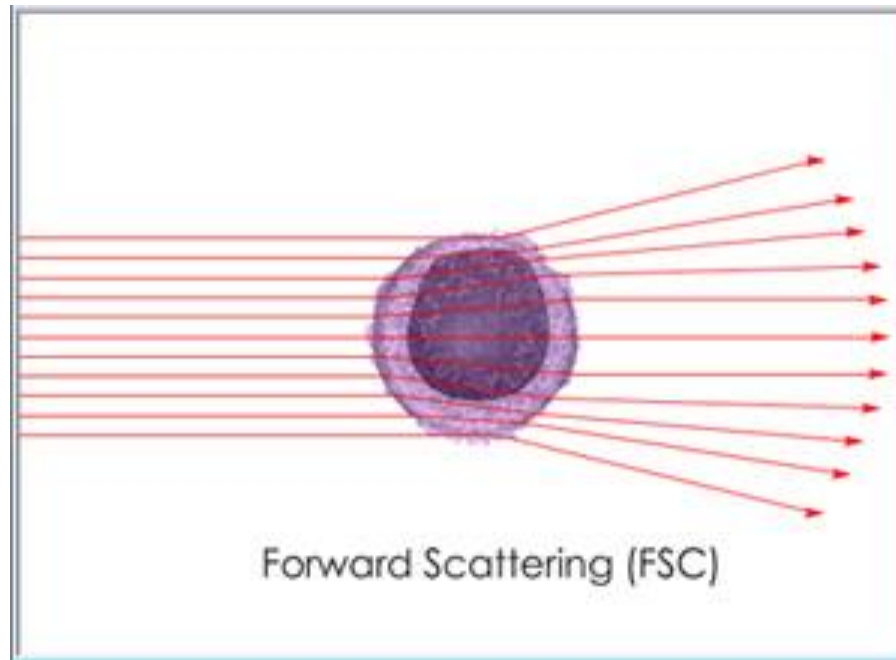

# Forward Scatter

- The **larger** the cell size, the **more** forward scatter is generated.

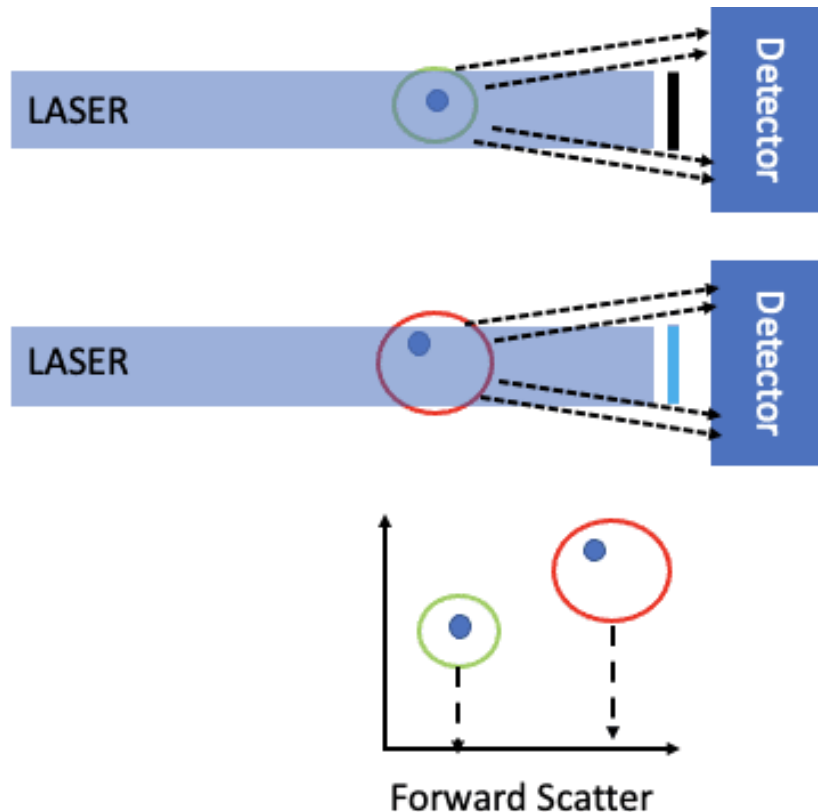

# Forward Scatter

- ✓ The **larger** the difference in RI between the cell and the surrounding sheath fluid, the **more** forward scatter is generated.

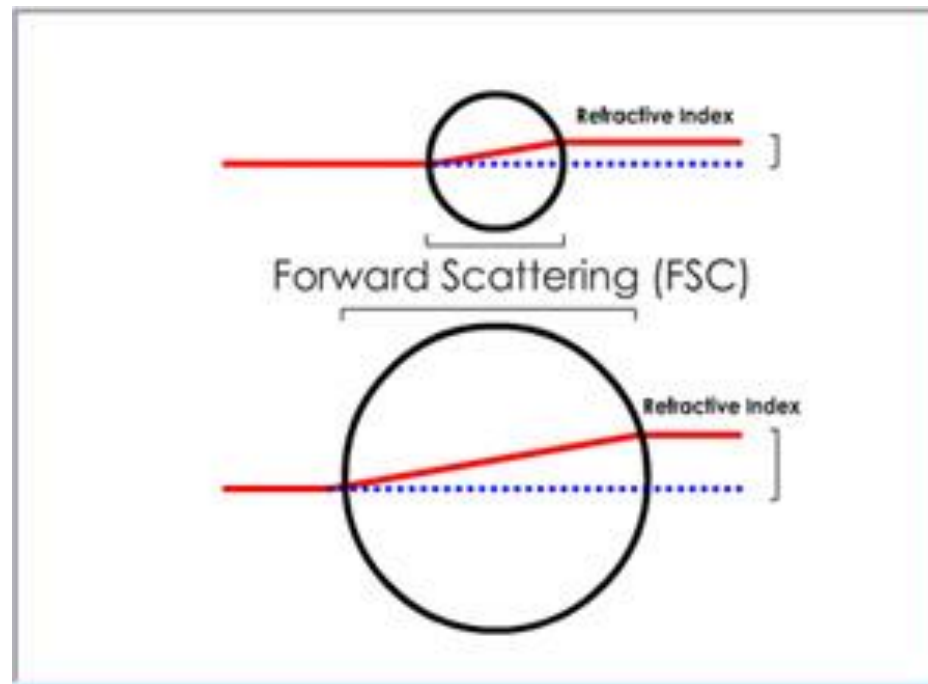

# Forward Scatter

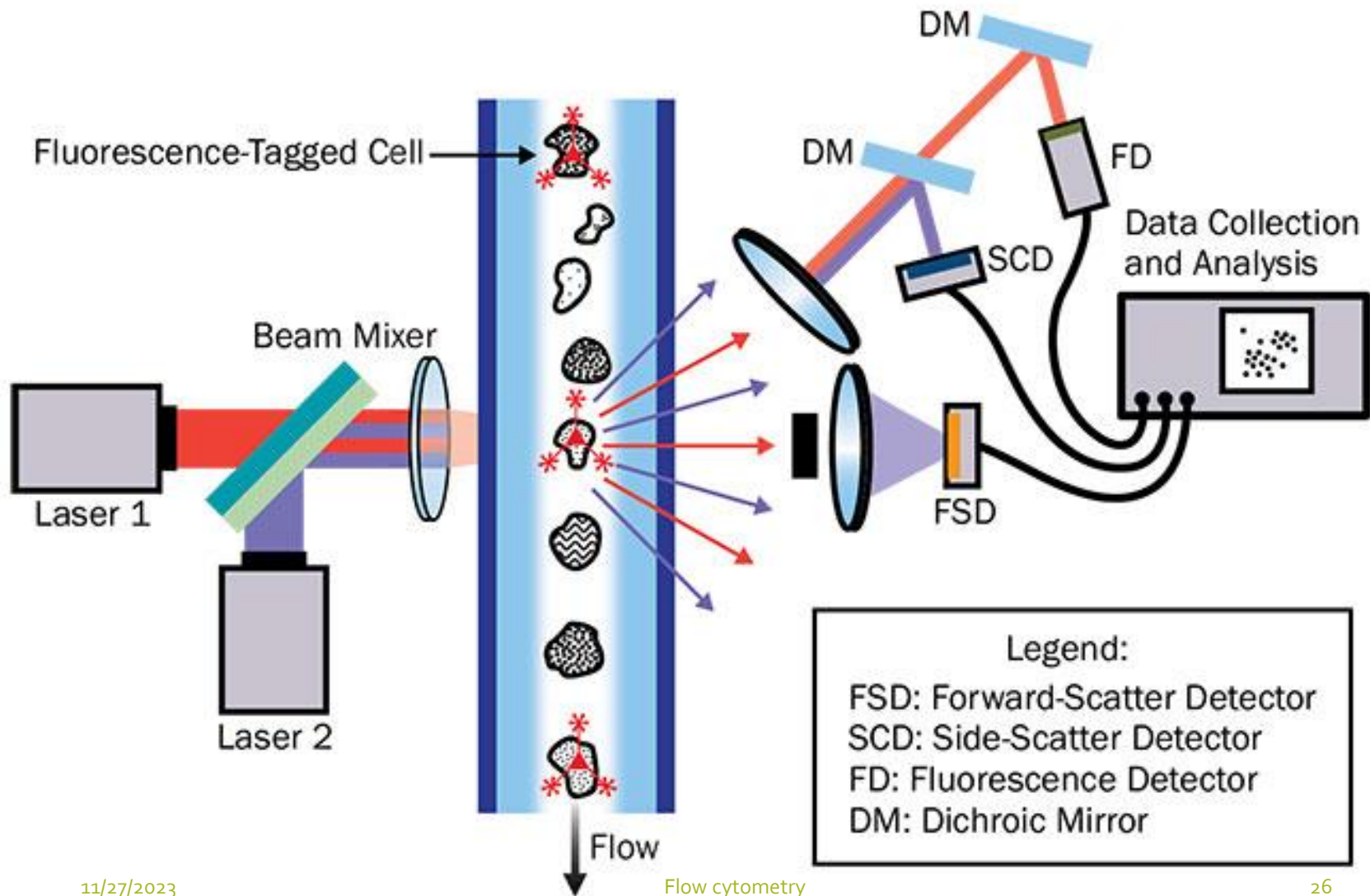

# Side Scatter

- Side Scatter light is based on the **granularity** or internal **complexity** of a particle.

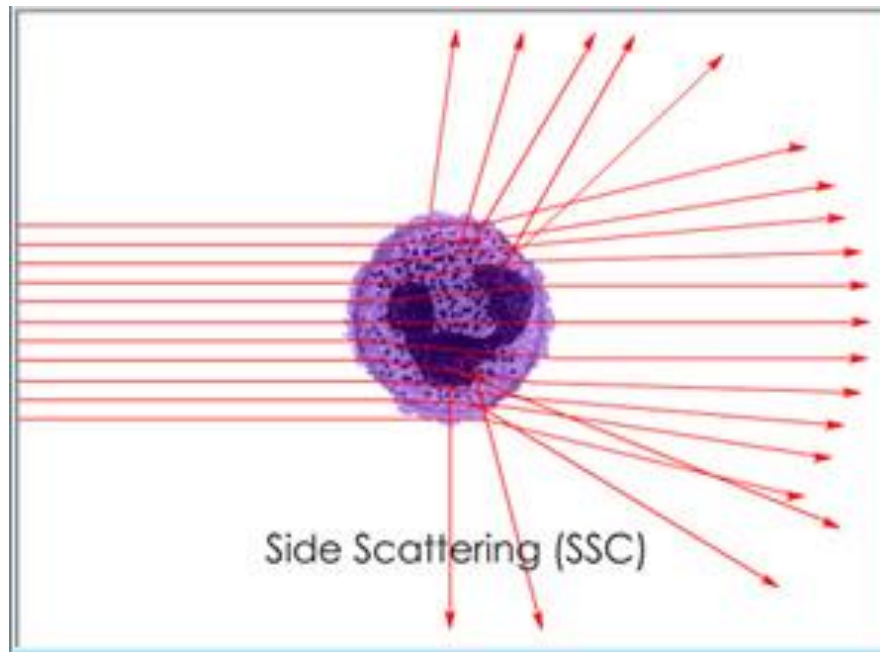

# Side Scatter

✓ The **more** granular the cell, the **more** side scatter light is generated as a cell or particle passes through a laser.

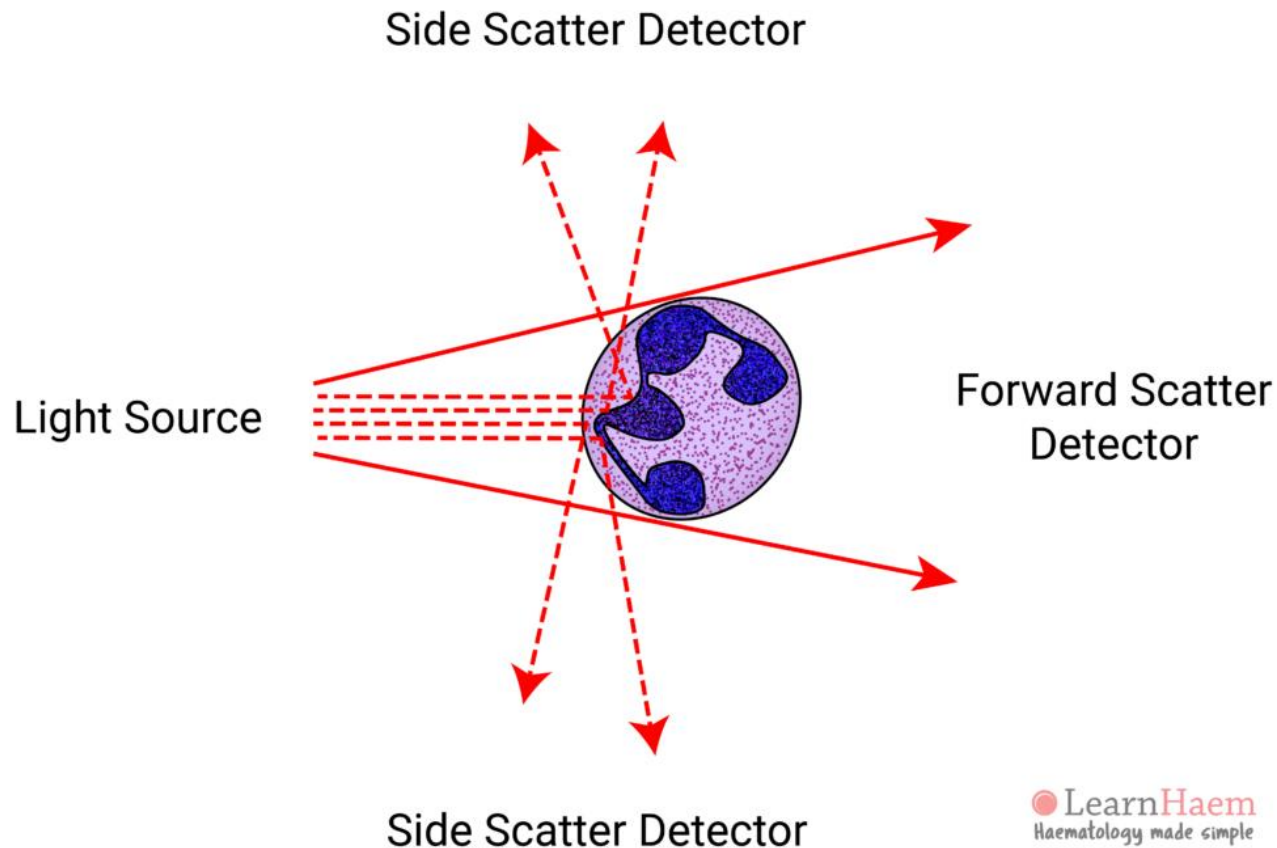

# Forward Scatter and Side Scatter of Blood Cells

- A cell's **size**, **refractive index**, and internal **complexity** contribute to the light that is scattered as a cell passes through a laser beam.
  
- **Proteins** on the cell membrane, the number of **nuclei**, and any granular materials or **organelles** inside the cell affect light scatter.

# Forward Scatter and Side Scatter of Blood Cells

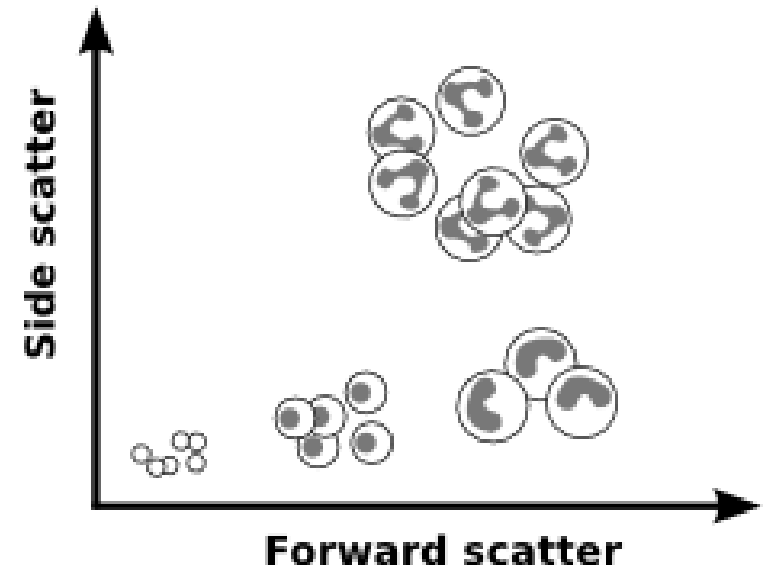
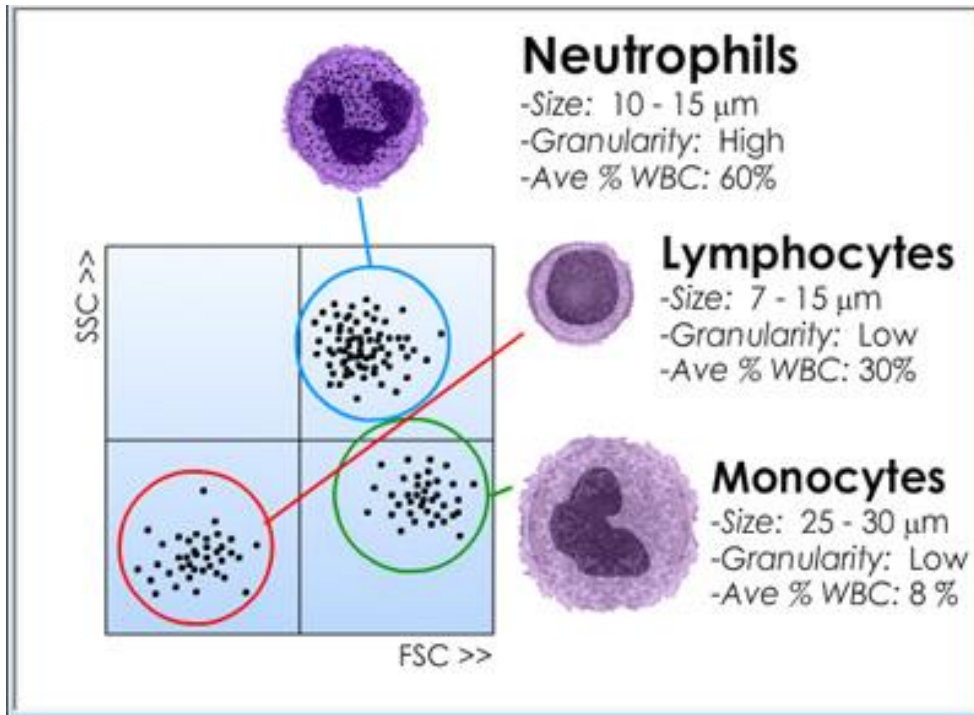

# Forward Scatter and Side Scatter of Blood Cells

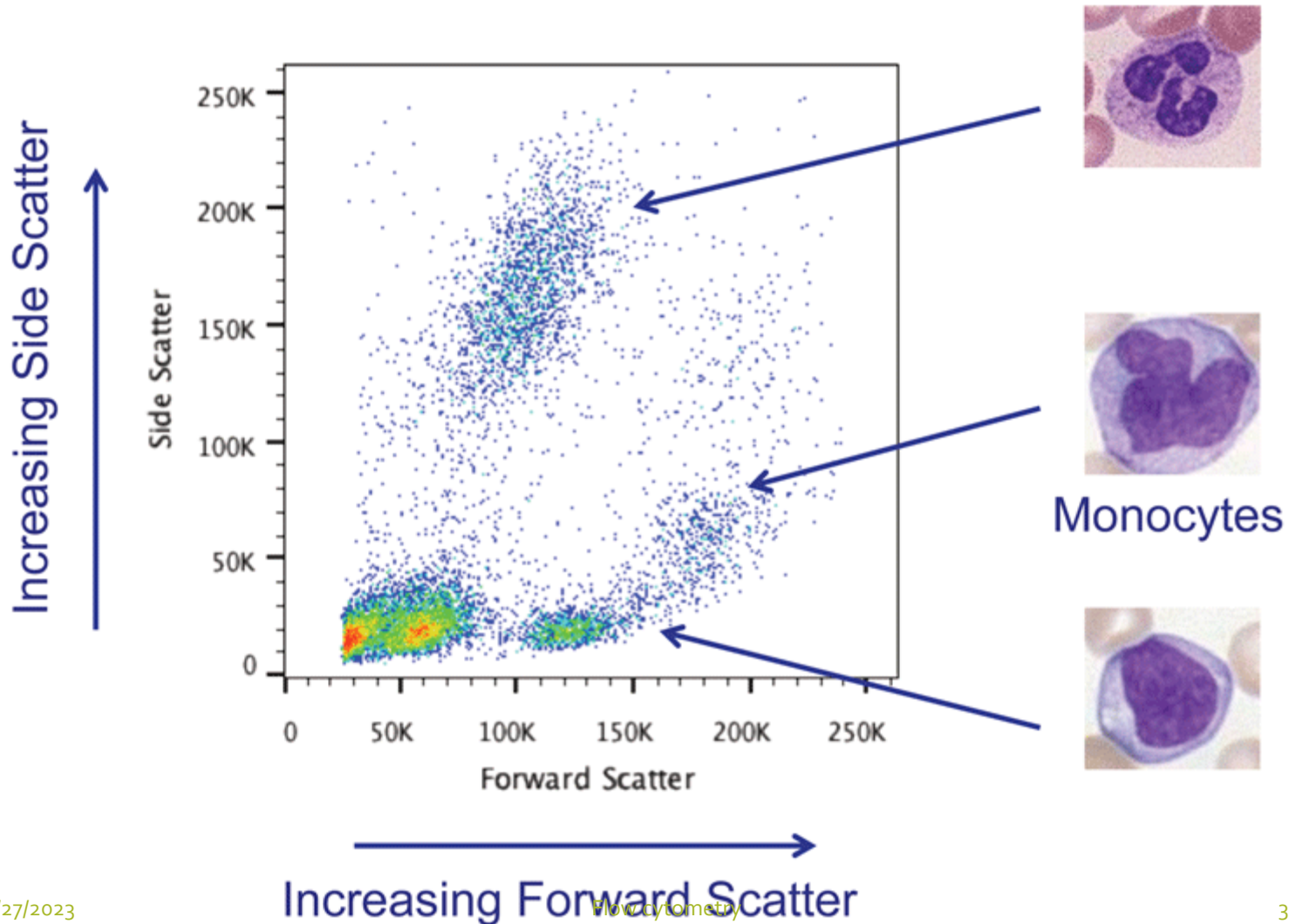

# Optic Subsystem Collection Components

❑ The positioned lenses collect scattered and fluorescent light.

❑ The collection components steer the scattered and fluorescent light to appropriate detectors.

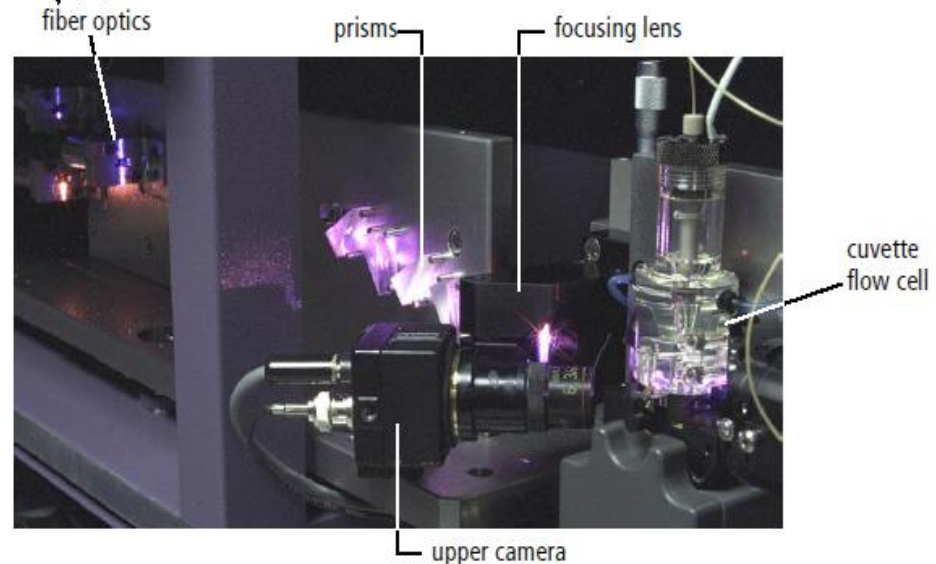
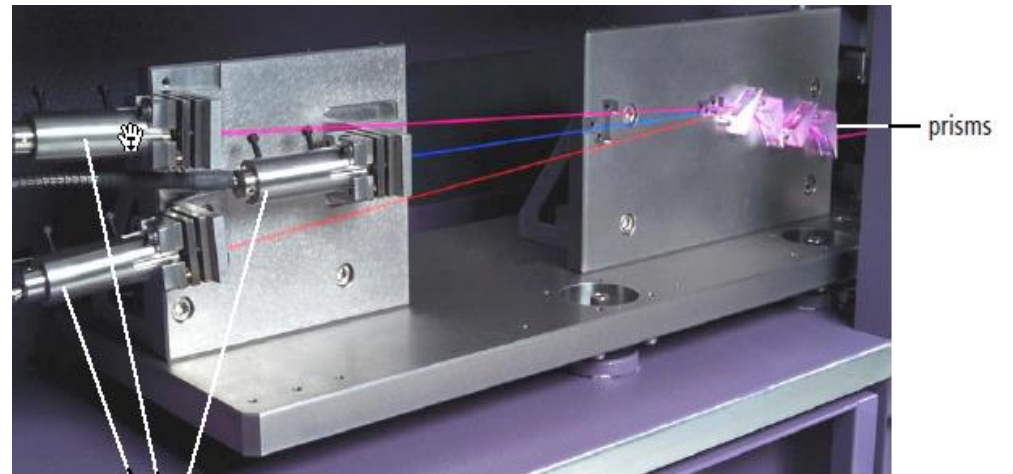

# Filters in Cytometers

- ❑ Optical filters are used to **direct** specific light wavelengths (or colors) to each photodetector. Filters are in three types:
  - I. **Longpass Filter:** transmits light that is equal to or longer than the specified wavelength.
  - II. **Shortpass Filter:** transmits light that is equal to or shorter than the specified wavelength.
  - III. **Bandpass Filter:** transmits light centered around the first value, within the range specified by the second value.

# Optic Subsystem

## Collection Components

### Dichroic Mirrors

Guide Scatters To Detectors

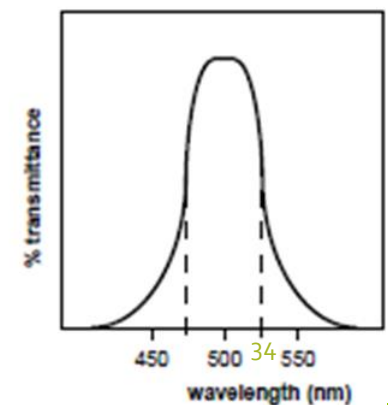
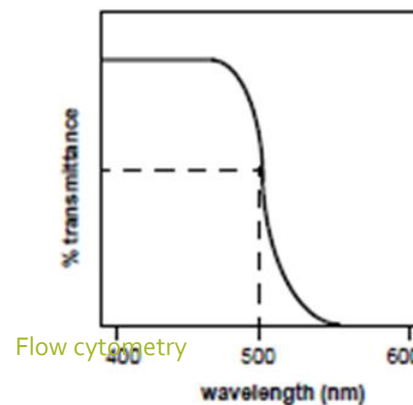
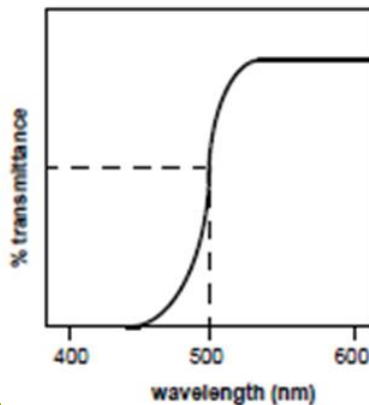
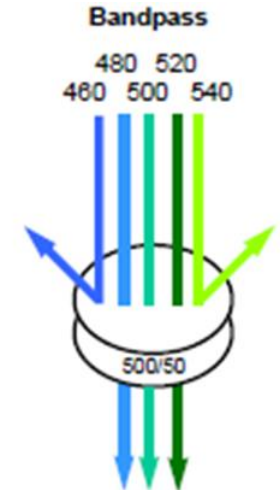
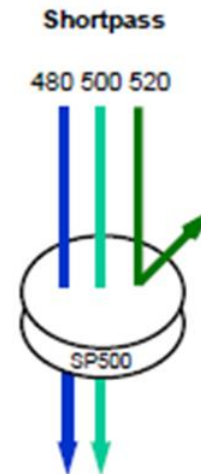
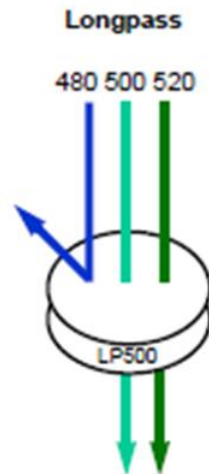

11/27/2023

Flow cytometry

34

# Cellular Markers and Monoclonal Antibodies

- ❑ With the use of **antibodies**, distinct cell population can be identified by the **markers** present on the cell surface.
- ❑ When a **fluorescent dye** is conjugated to a mAb, it can be used to identify a particular cell type based on the antigenic **markers** of the cell.
- ❑ A flow cytometer can detect blood cells based on the presence of mAbs with bound **fluorochromes**.

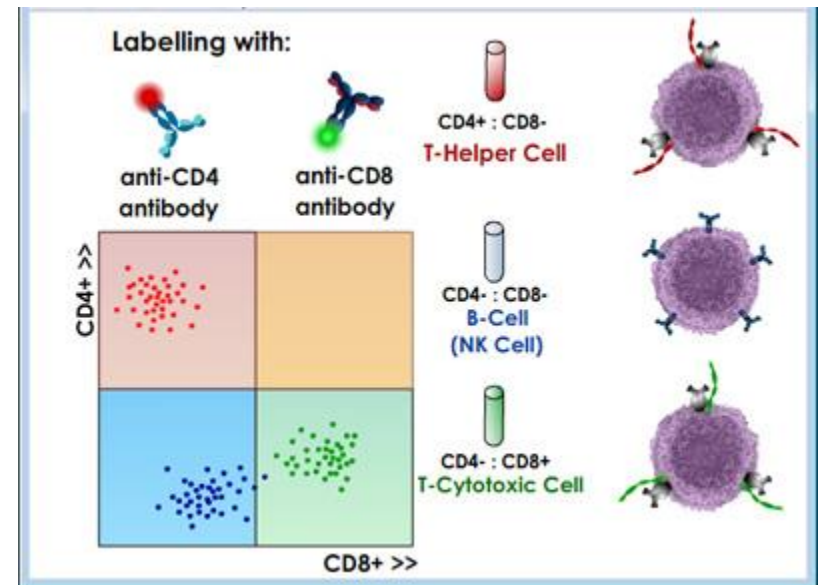

# Fluorescence & Photons

- ❑ The spectral range that is utilized in flow cytometry is between **~350 nm to ~800 nm**.
- ❑ The wavelength of visible light determines its “color”.

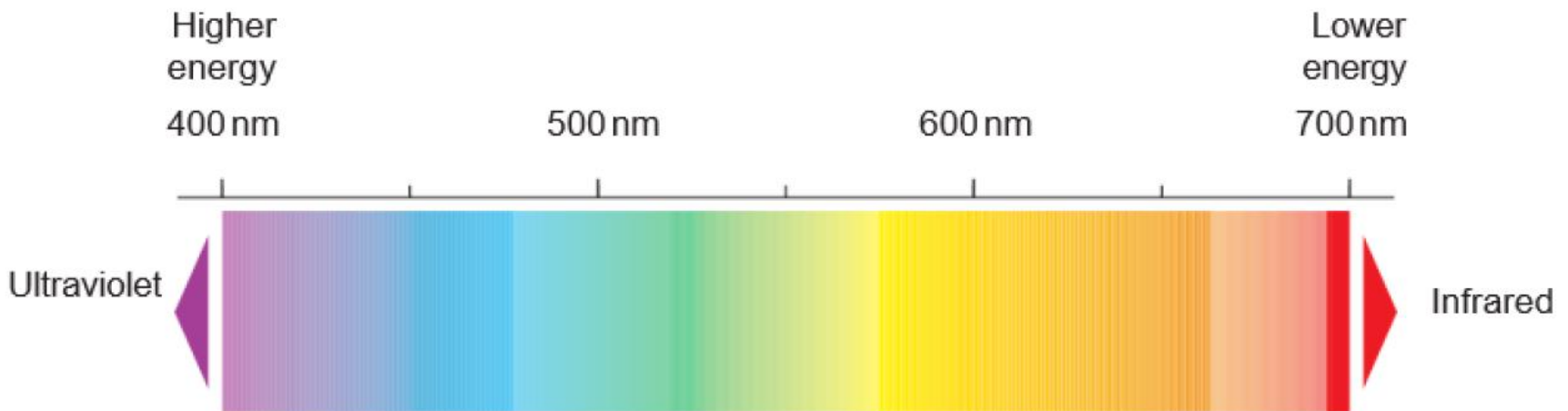

Visible spectrum

# Fluorescence & Photons

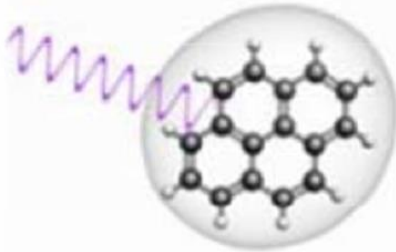

Absorption

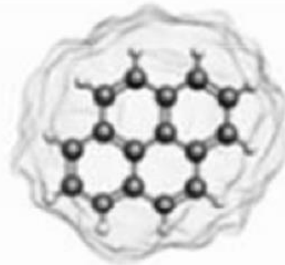

Excitation

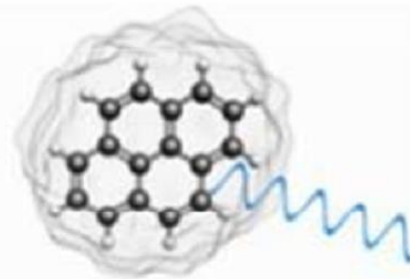

Emission

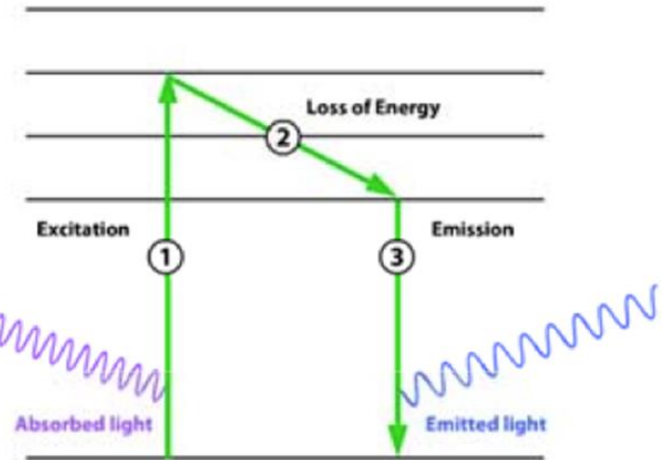

# Fluorescent Molecules

Sources of common fluorescent molecules

## Fluorescent proteins (organic)

Phycoerythrin (PE) - pigment found in seaweed



Green Fluorescent Protein (GFP) - often used as a surrogate for intracellular protein expression

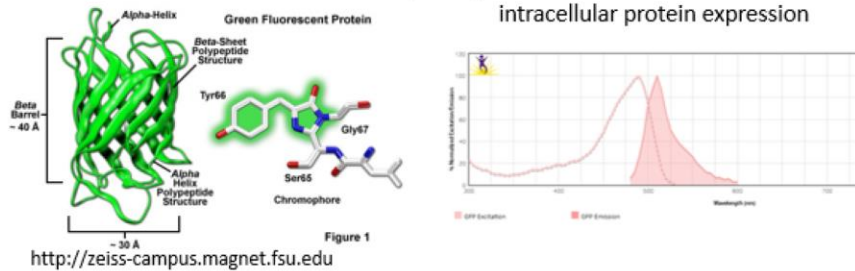

## Tandem dyes

Link 2 dyes together. 1 dye is excited and it's emitted light excites the 2<sup>nd</sup> dye.  
 The emission of the 2<sup>nd</sup> dye is detected.

11/27/2023

## Small synthetic molecules

Fluorescein isothiocyanate (FITC)

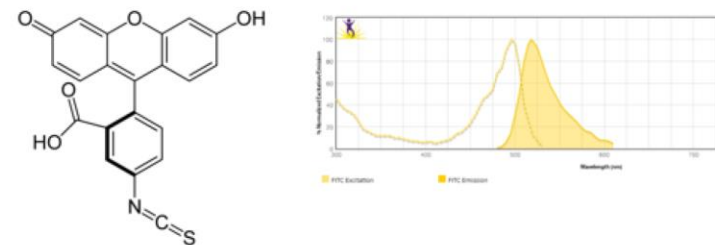

## Polymer dyes (inorganic)

Brilliant violet 421

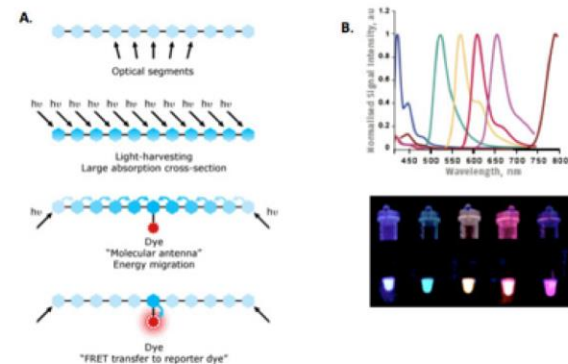

Flow cytometry

<https://expertcytometry.com/>

# Fluorescent Molecules

FLUOROCHROME	Type of molecule	Typical excitation laser	Approximate emission peak
Fluorescein isotyocyanate (FITC)	Small organic	488 nm	518 nm
AlexaFluor 488	Small organic	488 nm	518 nm
Phycoerythrin (PE)	Protein	488 or 532 nm	574 nm
PE-Texas Red	Protein tandem	488 or 532 nm	615 nm
PE-Cy5	Protein tandem	488 or 532 nm	665 nm
Peridinin chlorophyll protein (PerCP)	Protein	488 or 532 nm	676 nm
PerCP-Cy5.5	Protein tandem	488 or 532 nm	695 nm
PE-Cy7	Protein tandem	488 or 532 nm	776 nm
Allophycocyanin (APC)	Protein	633 nm	659 nm
AlexaFluor 647	Small organic	633 nm	667 nm
AlexaFluor 700	Small organic	633 nm	718 nm
APC-Cy7	Protein tandem	633 nm	784 nm
Pacific Blue	Small organic	405 nm	454 nm
AmCyan	Protein	405 nm	487 nm

11/27/2023

Flow cytometry

39

# Electronics System

- **The main functions of the electronics system are to:**
  - I. Convert light signals into numerical data.**
  - II. Eliminate small signal events such as noise and debris through threshold.**
  - III. Attribute signals from multiple lasers to the correct cell or particle.**

# Electronics Subsystem

- ❑ The detectors in the electronics subsystem convert detected light into proportional **electronic signals**.
- ❑ Electronic signals are then digitized, further processed, and sent to the **computer**.
- ❑ Data for each cell or particle is stored in the computer and plotted in various ways for further analysis.

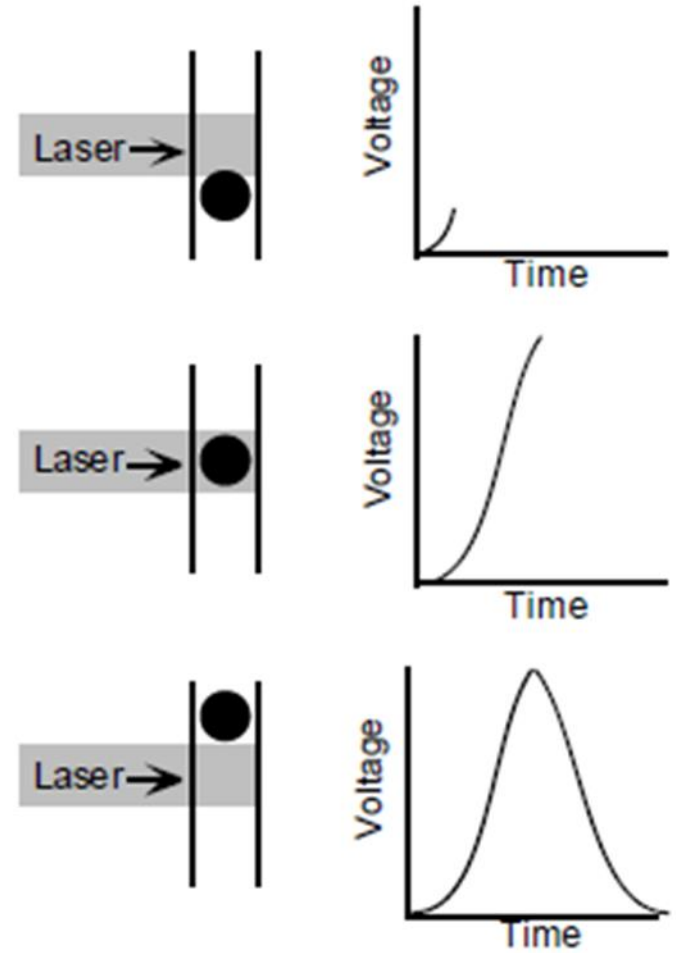

# How Is Light Converted Into Data?

- ❑ To convert light into data, three components are needed:

**Photodetectors, Amplifiers, and Signal Processors.**

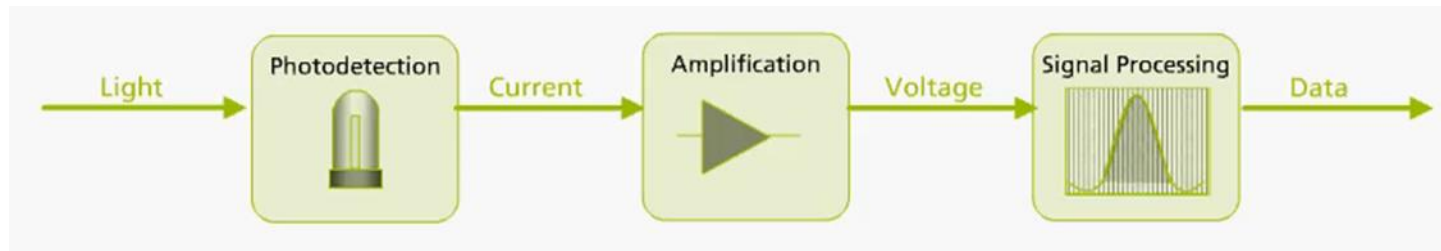

- ❑ These electronic components work in a sequence to convert **light** into **current**, current into **voltage**, and voltage into **data** that can be further analyzed.

# Photodetection

- ❑ Photodetectors are light **sensors** that can detect photons of light.
- ❑ Incoming photons cause photodetectors to produce **electrical current**.

## ❑ **Types of photodetectors:**

**I. Photodiode**

**II. Avalanche Photodiode**

**III. PhotoMultiplier Tube (PMT)**

# Photodetection

## Photomultiplier tubes (PMT)

- ✓ “Old” but good technology
- ✓ The most common detector used in flow
- ✓ High sensitivity but poor quantum efficiencies in red ( $>650\text{nm}$ )
- ✓ Able to adjust the gain to over 100,000
- ✓ Common
- ✓ Inexpensive



## Photodiode (PD)

- ✓ New[er] technology, still not common
- ✓ High quantum efficiencies for visible
- ✓ No internal gain adjustment
- ✓ Requires Cooling
- ✓ Require a high voltage bias

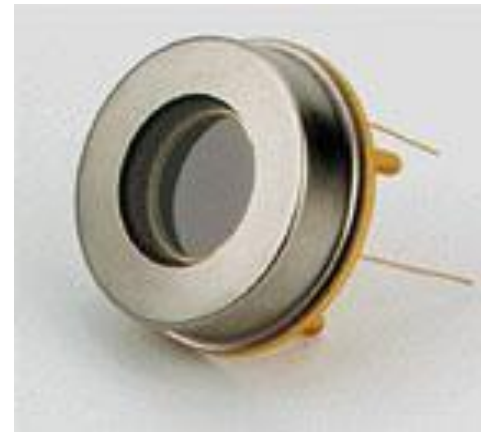

# Amplification

- ❑ Amplifiers convert electrical **current** from photodetectors into a **voltage**.
- ❑ The resulting voltage are **larger** in magnitude than the incoming currents.

# Signal Processing

- Signal Processors quantify voltage pulses, providing **numerical values** for pulse height, width, and area.

# Signal Processing

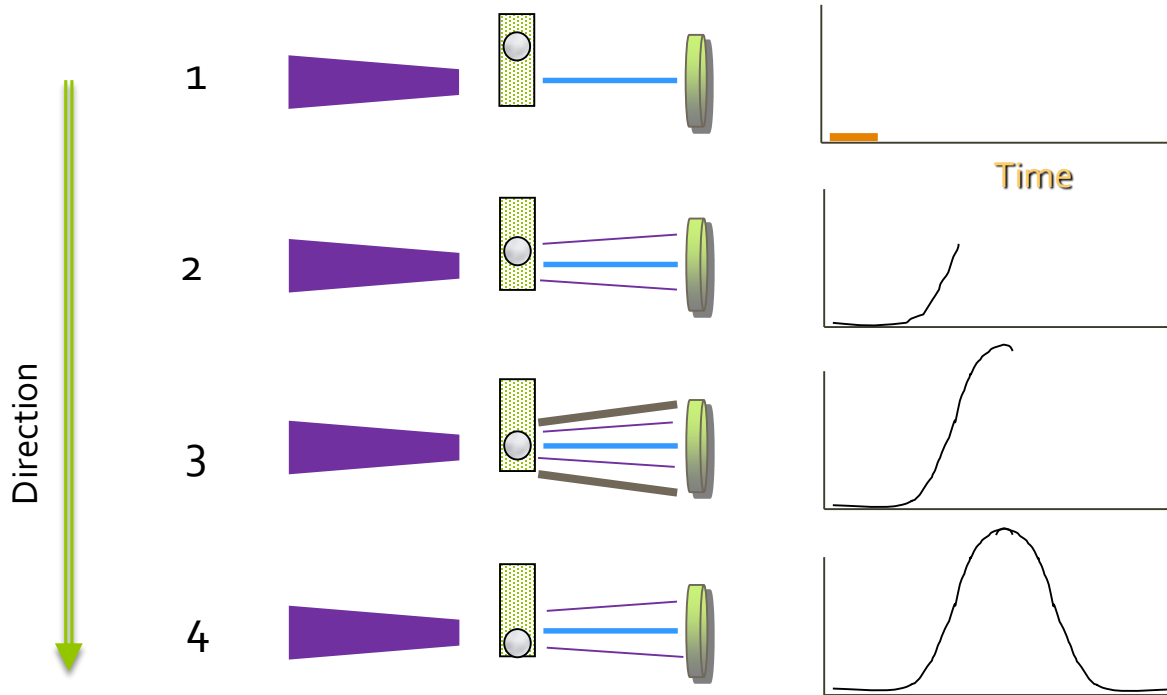

**Width** is useful for doublet  
Cell discrimination in analysis

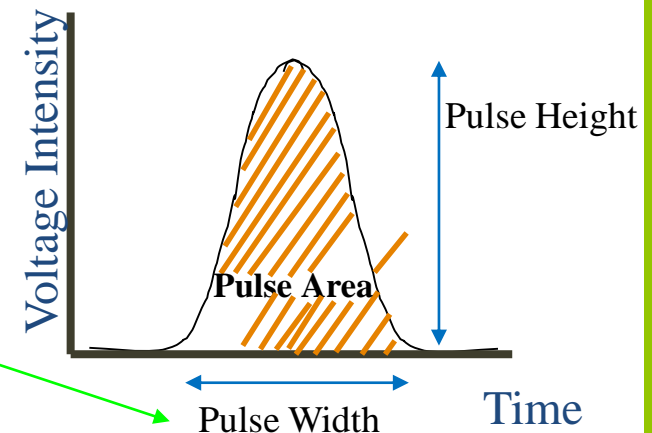

# Data Display in Different Plot Types

## □ Histogram Plot:

- ✓ Display a single parameter against the number of events (counts).
- ✓ Events with higher fluorescence intensity appear to the right on the X-axis.

## □ Dot Plot:

- ✓ Displays two parameters simultaneously.
- ✓ Each dot represents one or more events.
- ✓ Dots appear farther to the right on the X-axis or higher on the Y-axis as signal intensity increases.

# Histogram Plot

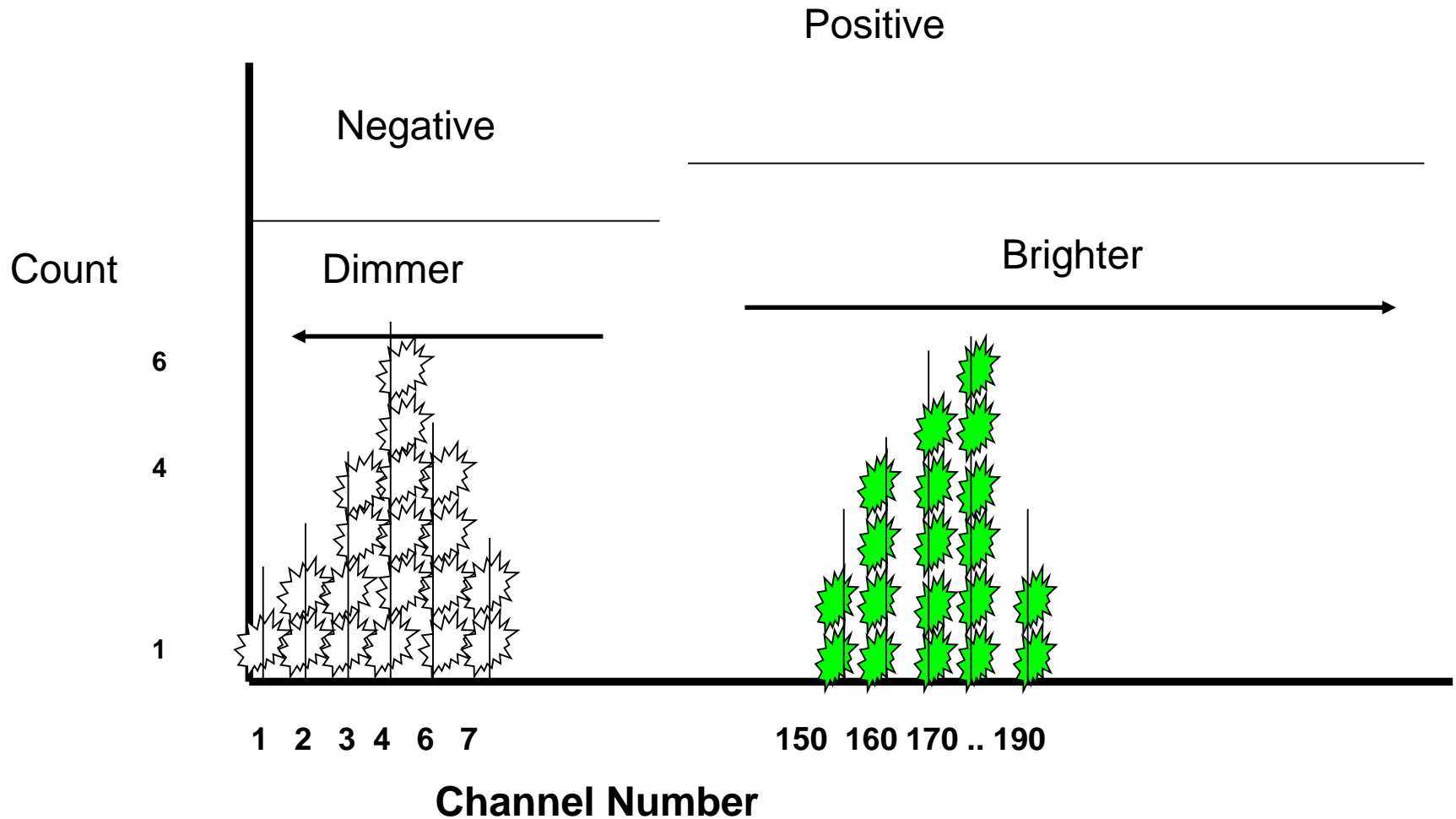

Fluorescence picked up from the FITC PMT

# Histogram Plot

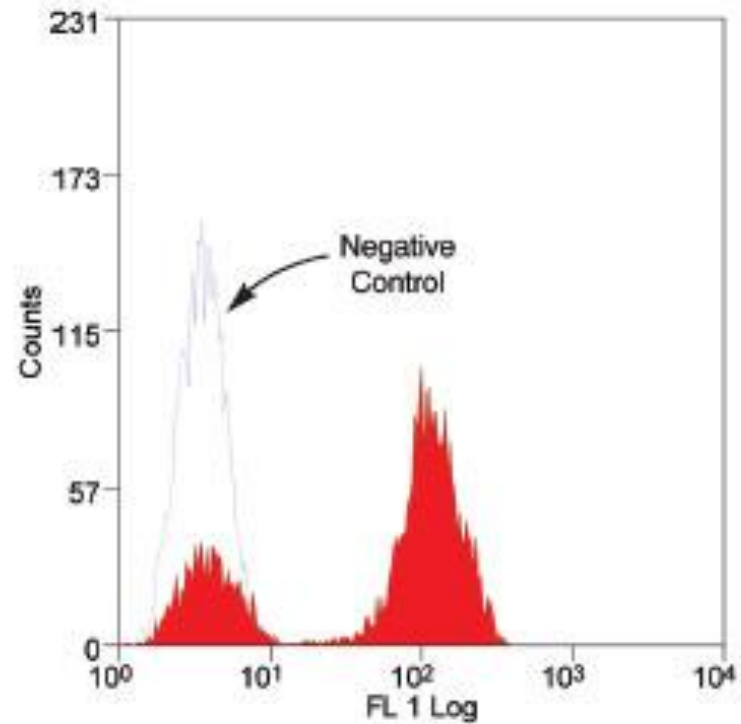
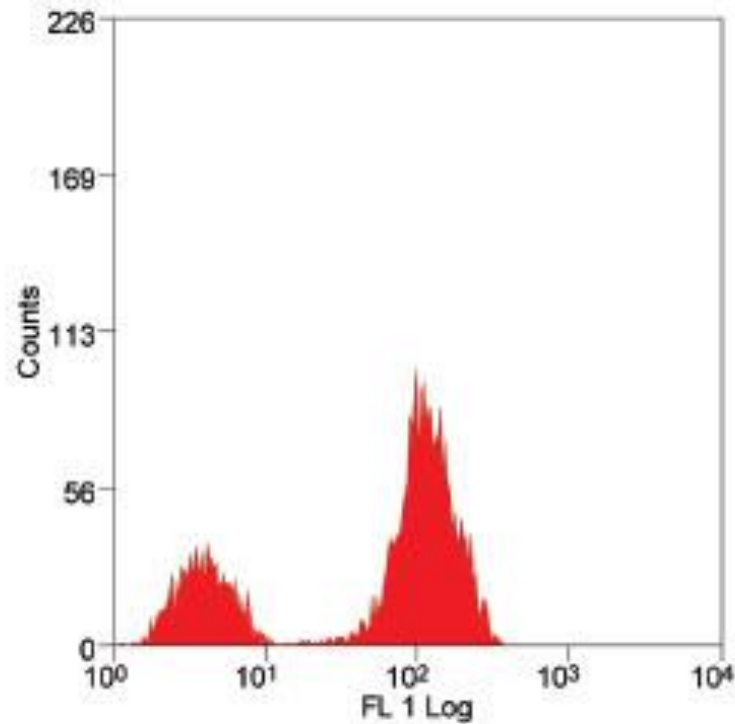

# Histogram Plot

## Fluorescence One Color Histogram

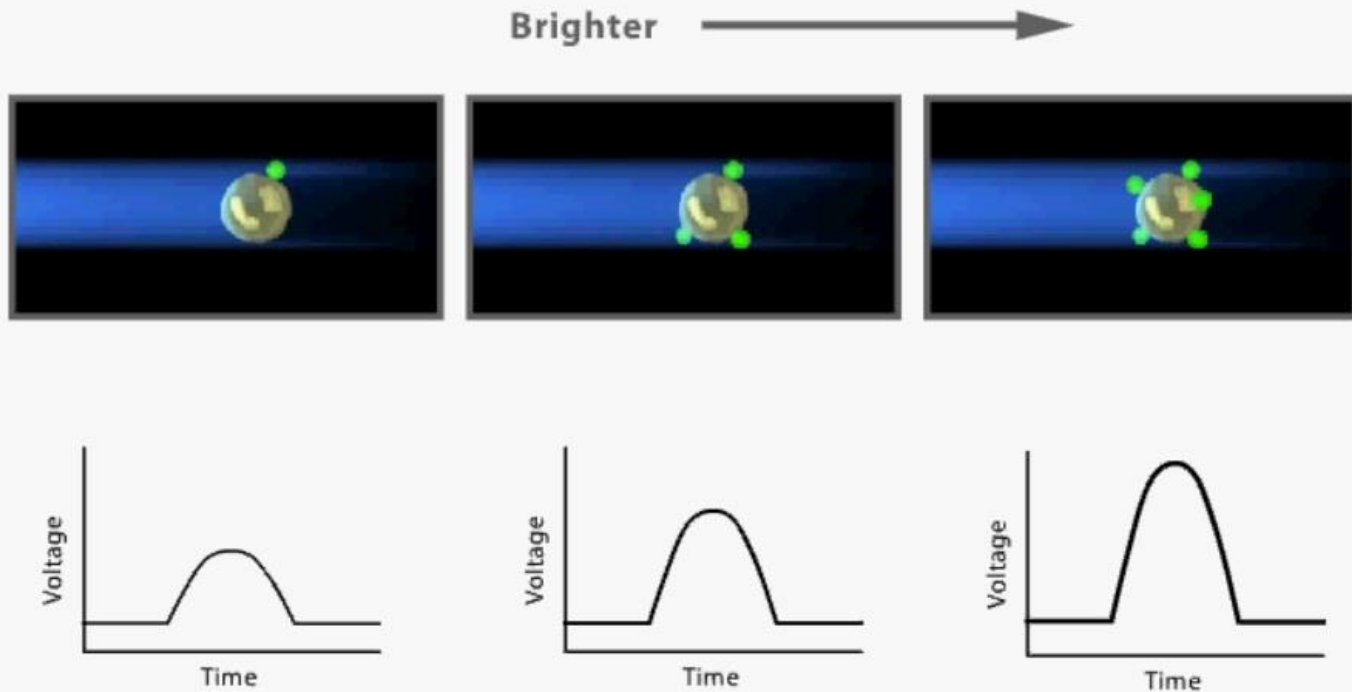

# Histogram Plot

- ✓ The place of cells in plots is depended on their **fluorescence intensity** or Heights of signals in detectors.

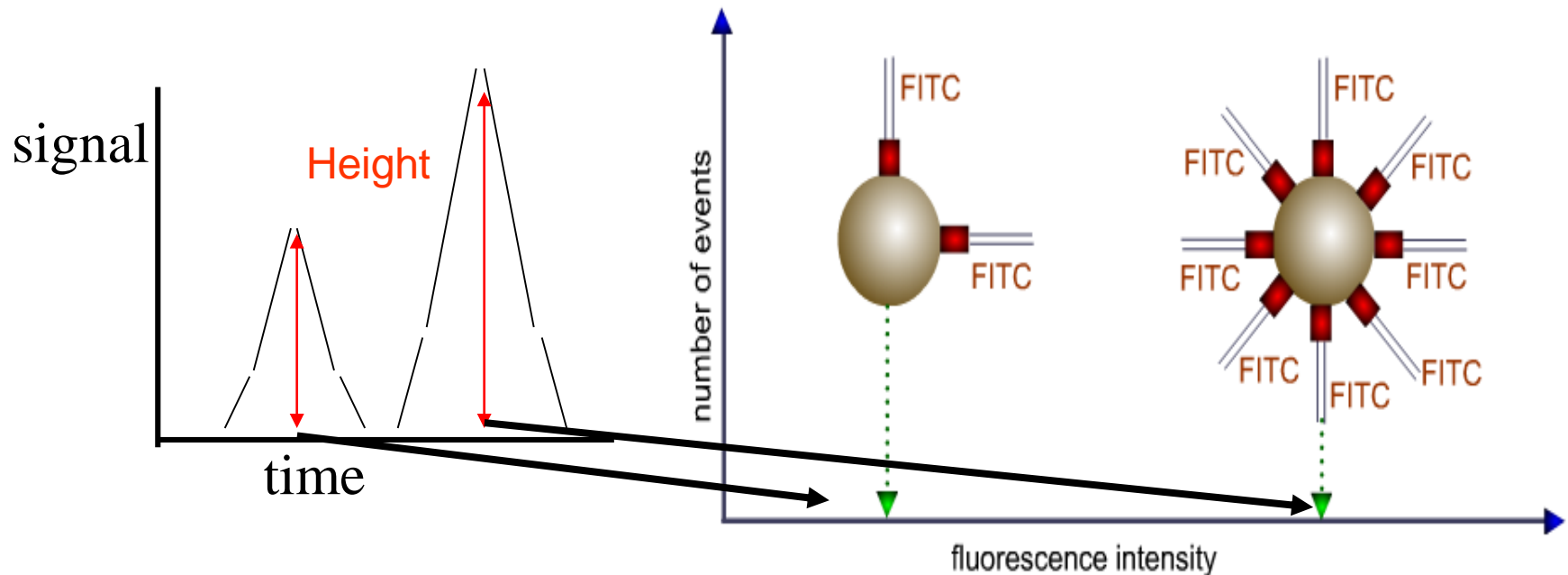

# Dot Plot

- Each Dot is a cell
- Use to inspection of cell condition for two parameter, FSC vs SSC or FITC vs PE

	FSC	SSC	FITC	PE
event 1	30	60	638	840
event 2	100	160	245	85
event 3	300	650	160	720

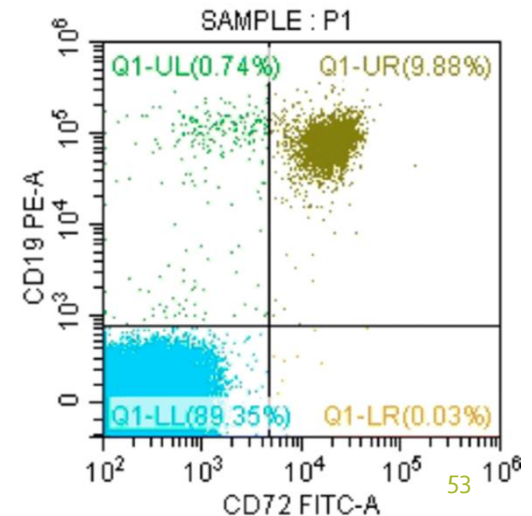
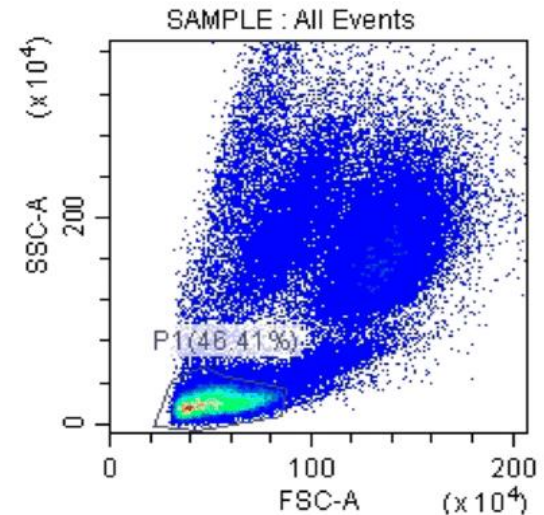
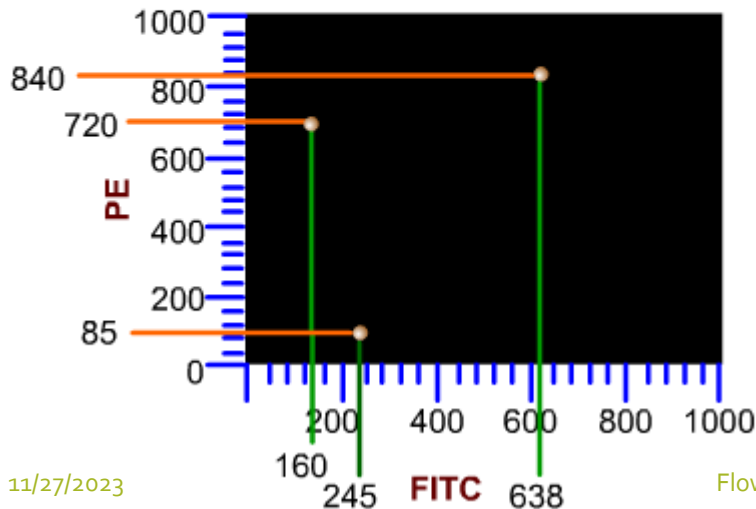

# Dot Plot

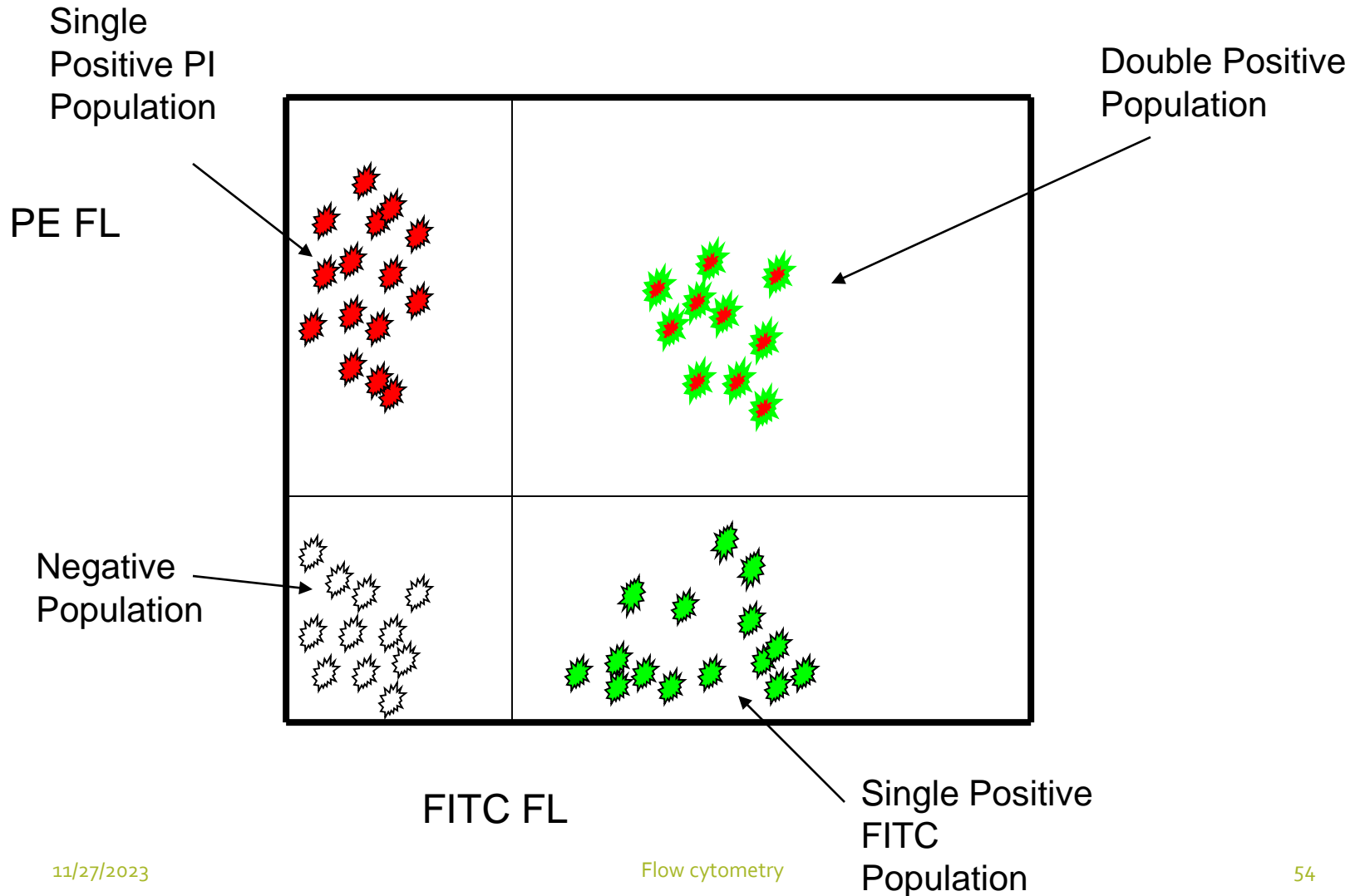

# Data Display in Different Plot Types

## □ Density Plot:

- ✓ Provides a third dimension using color to indicate the event count, similar to contour on a contour plot.
- ✓ Dots for coordinates with the same event count are given the same color.
- ✓ Dots appear farther to the right on the X-axis or higher on the Y-axis as signal intensity increases.

## □ Contour Plot:

- ✓ Displays two parameters simultaneously.
- ✓ Contour lines provide a third dimension by joining X- and Y-coordinates with similar event counts (similar to topographical maps).

# Density Plot

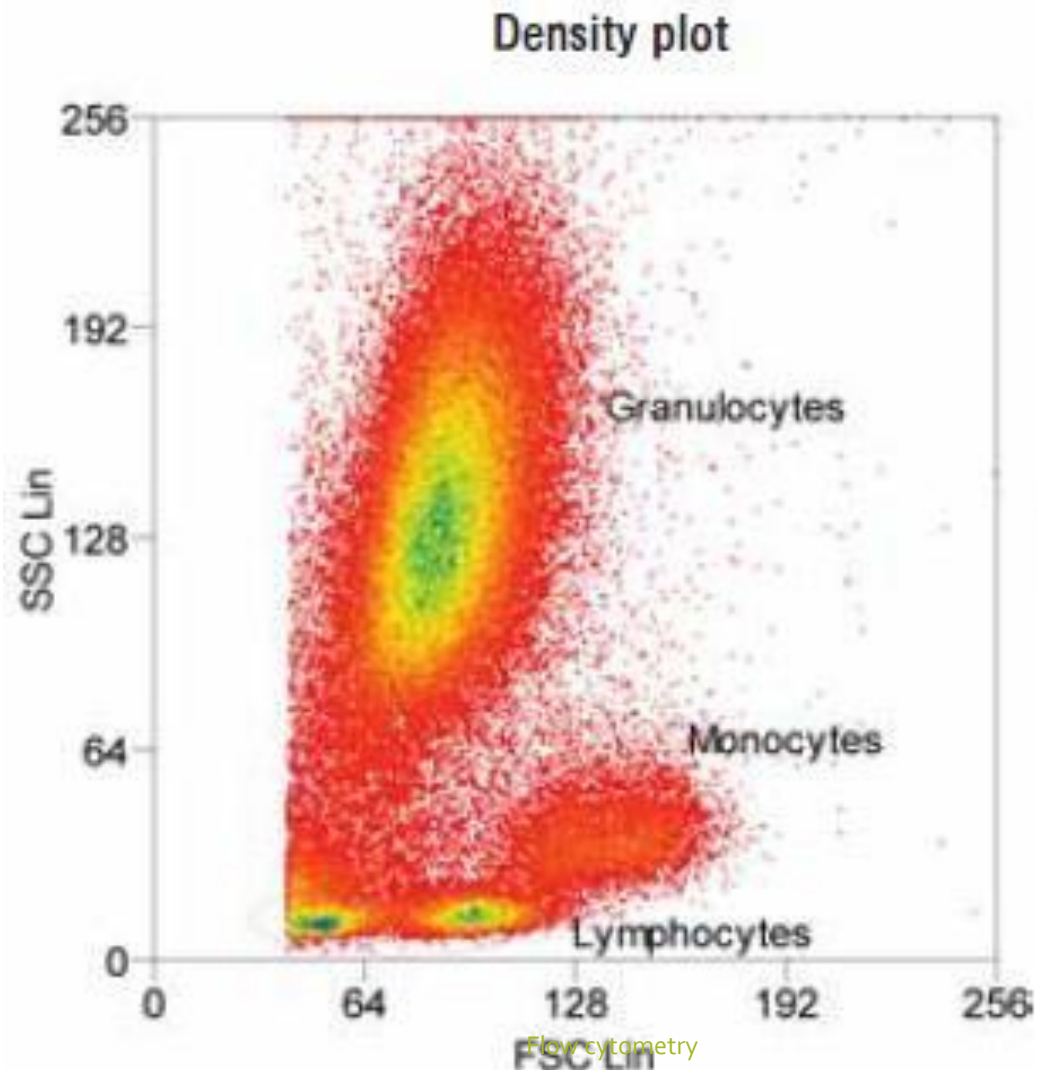

# Contour Plot

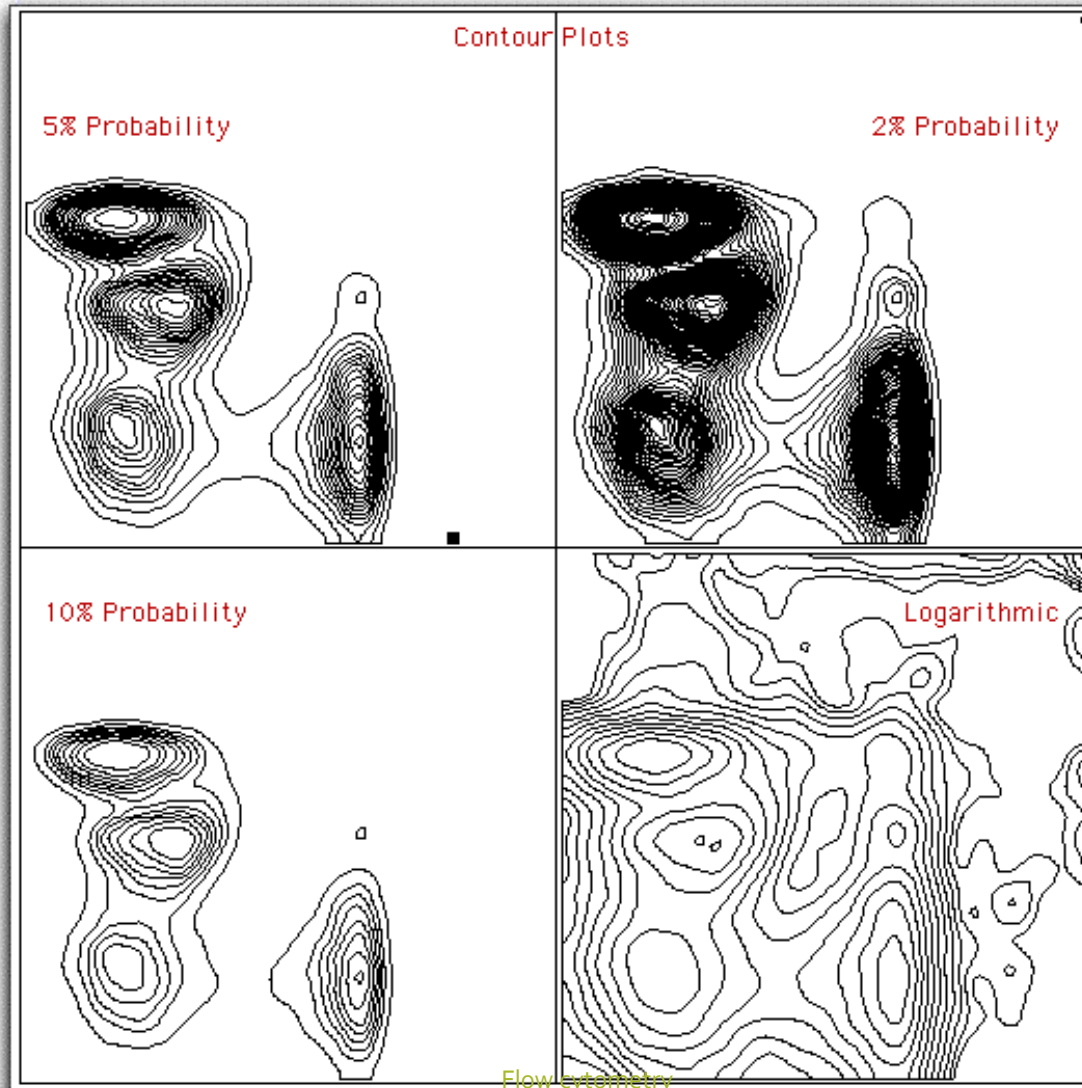

# Gating

- ❑ A gate is a numerical or graphical **boundary** that can be used to define characteristics to include for further analysis.
- ❑ Gates are used to identify **subsets** of data, or populations.
- ❑ Populations defined by gates can be used to generate **statistics** and **limit** the number of events collected or saved.

# Gating

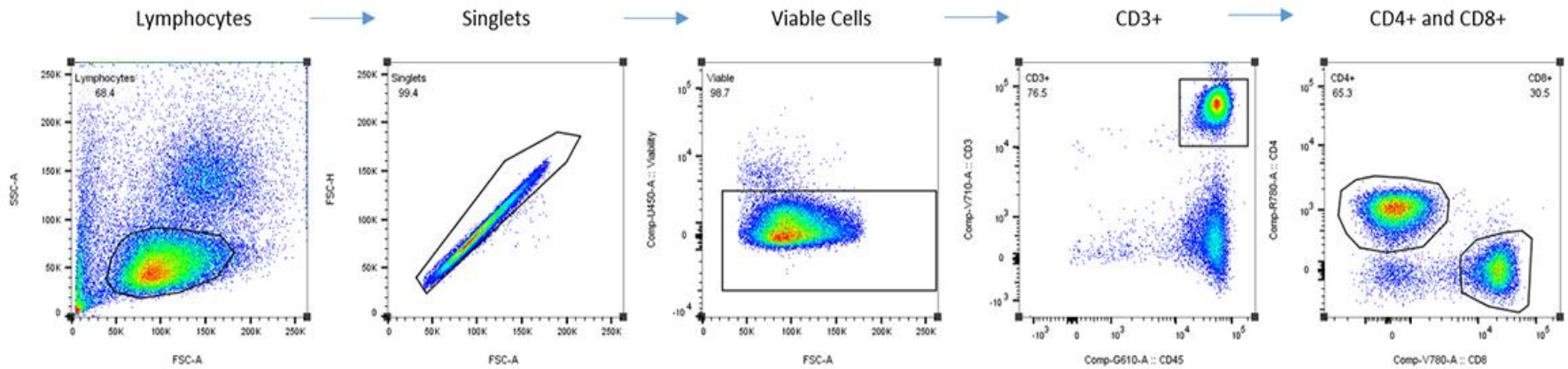

A representative Nested Gating Strategy illustrating lymphocyte population being subgated to the level of CD4+ and CD8+ T Cells.

# Spectral Overlap

- ❑ More than one fluorochrome can be used **simultaneously** to identify cells in a sample tube.
- ❑ Emission spectra of the fluorochromes may **overlap** each other and **bleed** into the detection filters for other fluorochromes. This is called **spectral overlap**.

# How to Correct for Spectral Overlap between Fluorochromes?

## Compensation – Separation of colors

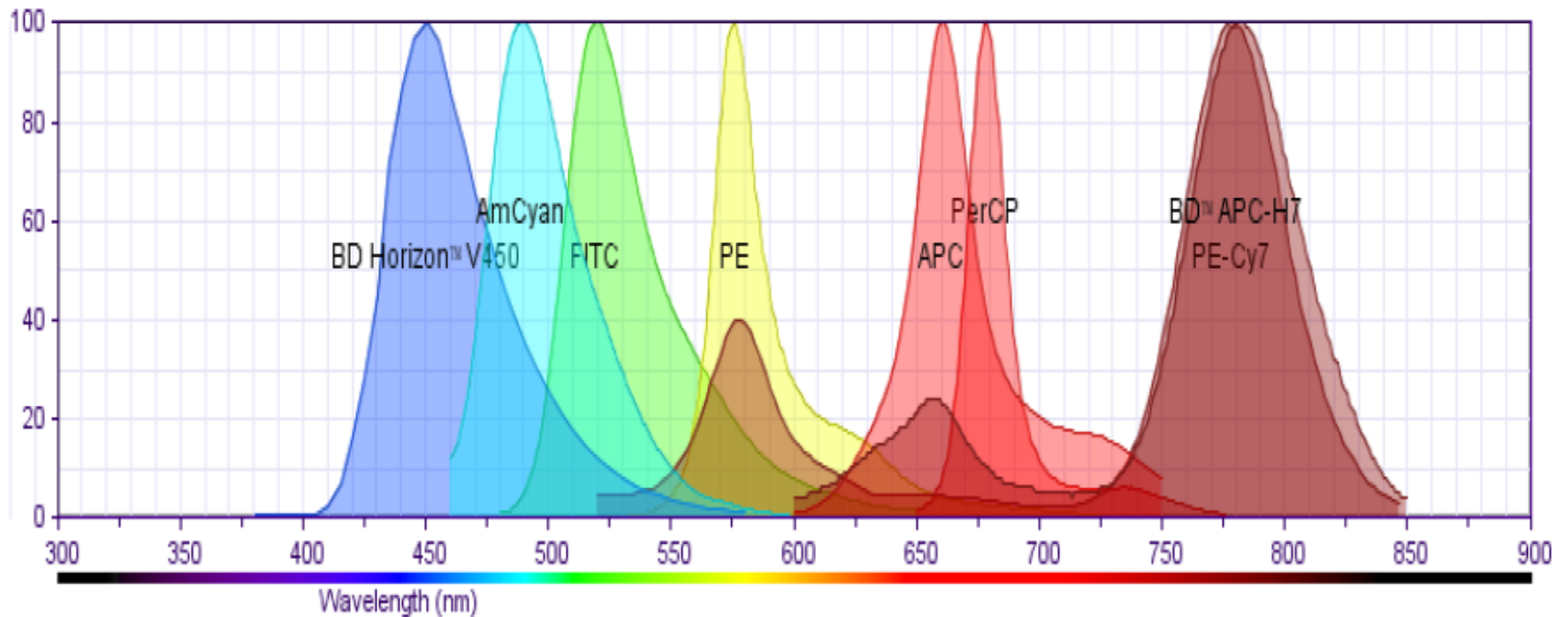

# How to Correct for Spectral Overlap between Fluorochromes?

- ❑ To accurately record the fluorescence signal for a given fluorochrome, you need to correct the emission signal, and this correction is often called **compensation**.
- ❑ Compensation allows you to distinguish cells or particles that are **truly positive** for specific fluorochromes from those that appear to be positive due to spillover into other detectors.
- ❑ In order to see the amount of compensation required to correct the fluorescence, you need **single-color** samples such as aliquots of the cell sample stained with each fluorochrome separately.

# How to Correct for Spectral Overlap between Fluorochromes?

Uncompensated

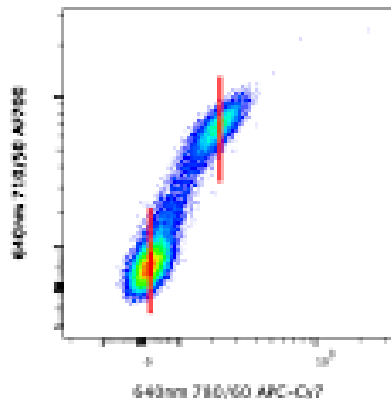

Compensated

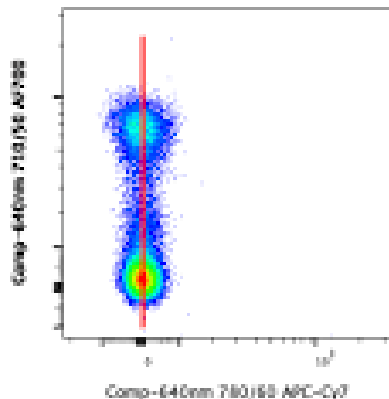

## Compensation

Decrease the false positive events for every parameter because of overlap in band of spectra

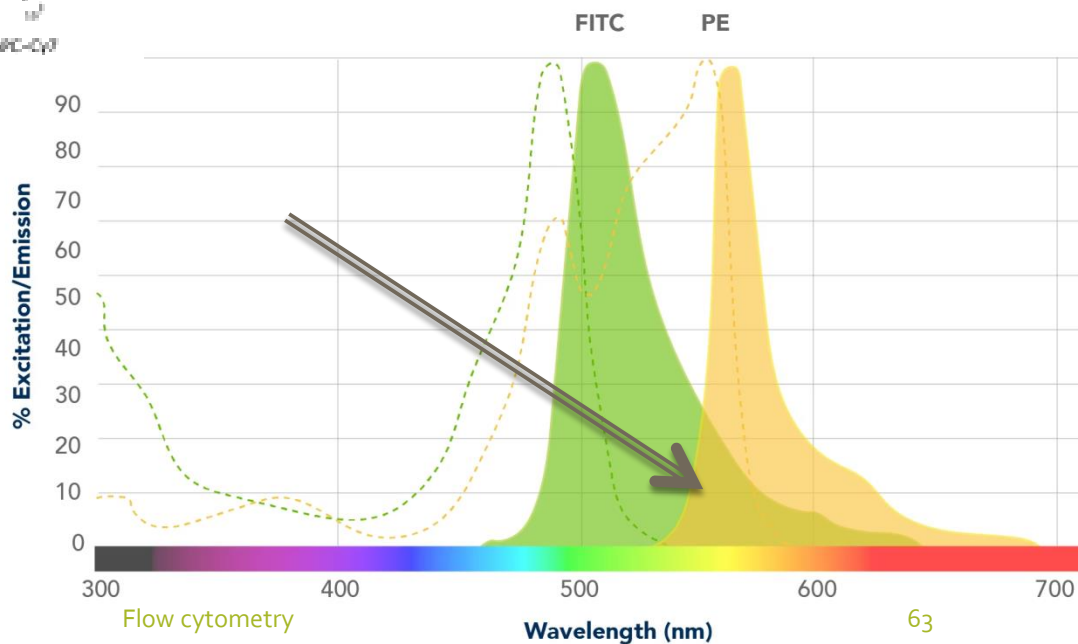
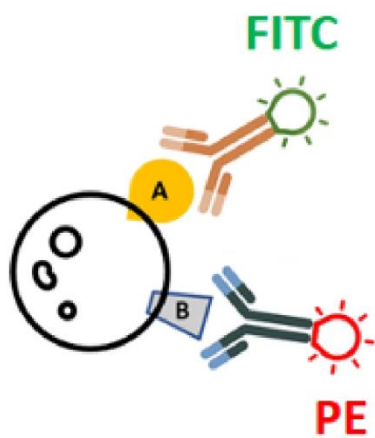

# How to Correct for Spectral Overlap between Fluorochromes?

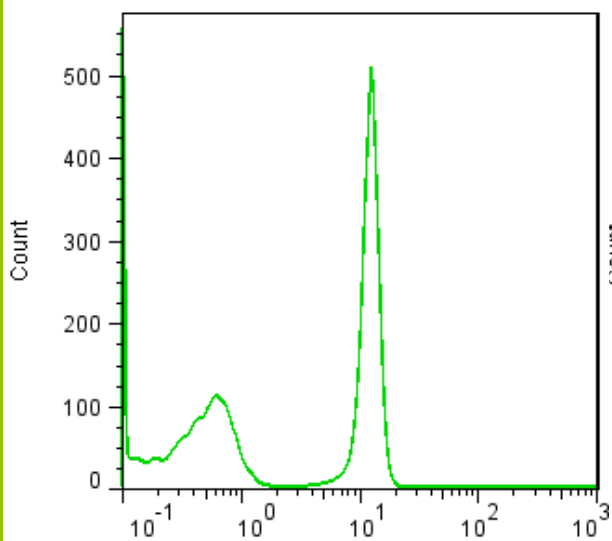

FL1:: FITC

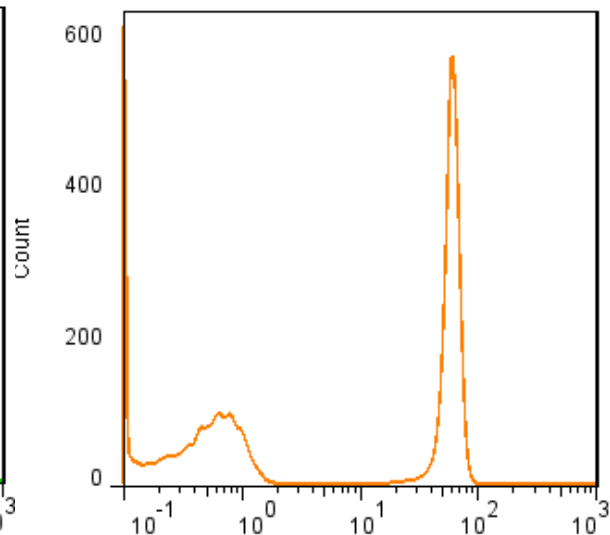

FL2:: PE

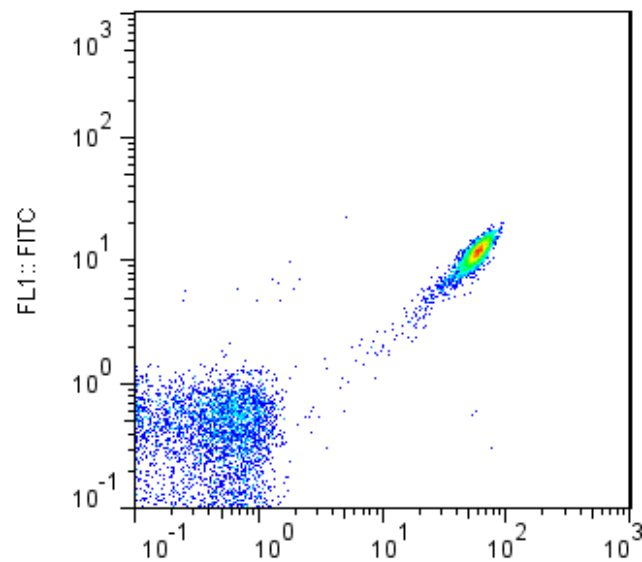

FL2:: PE

# How to Correct for Spectral Overlap between Fluorochromes?

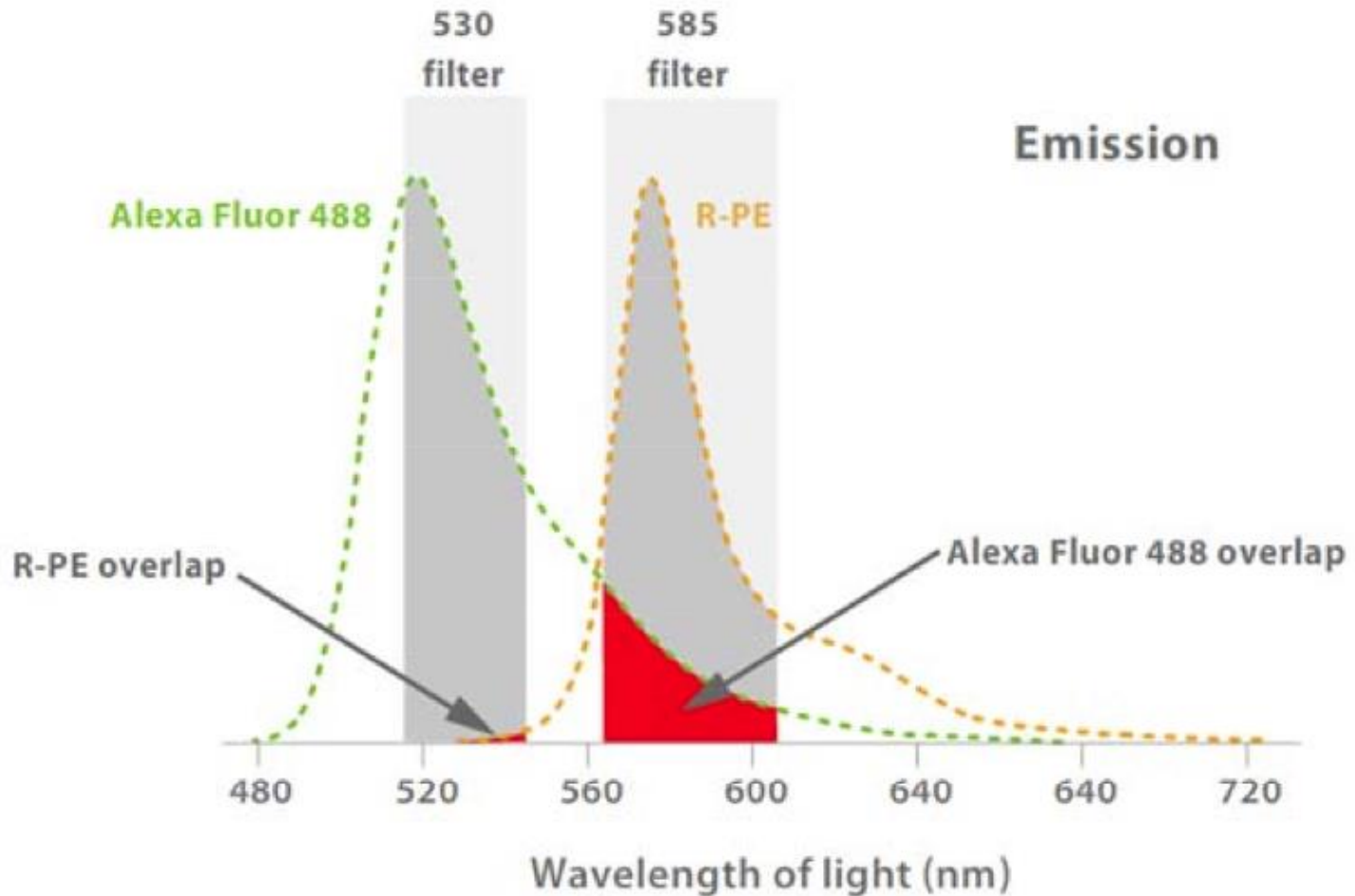

# How to Correct for Spectral Overlap between Fluorochromes?

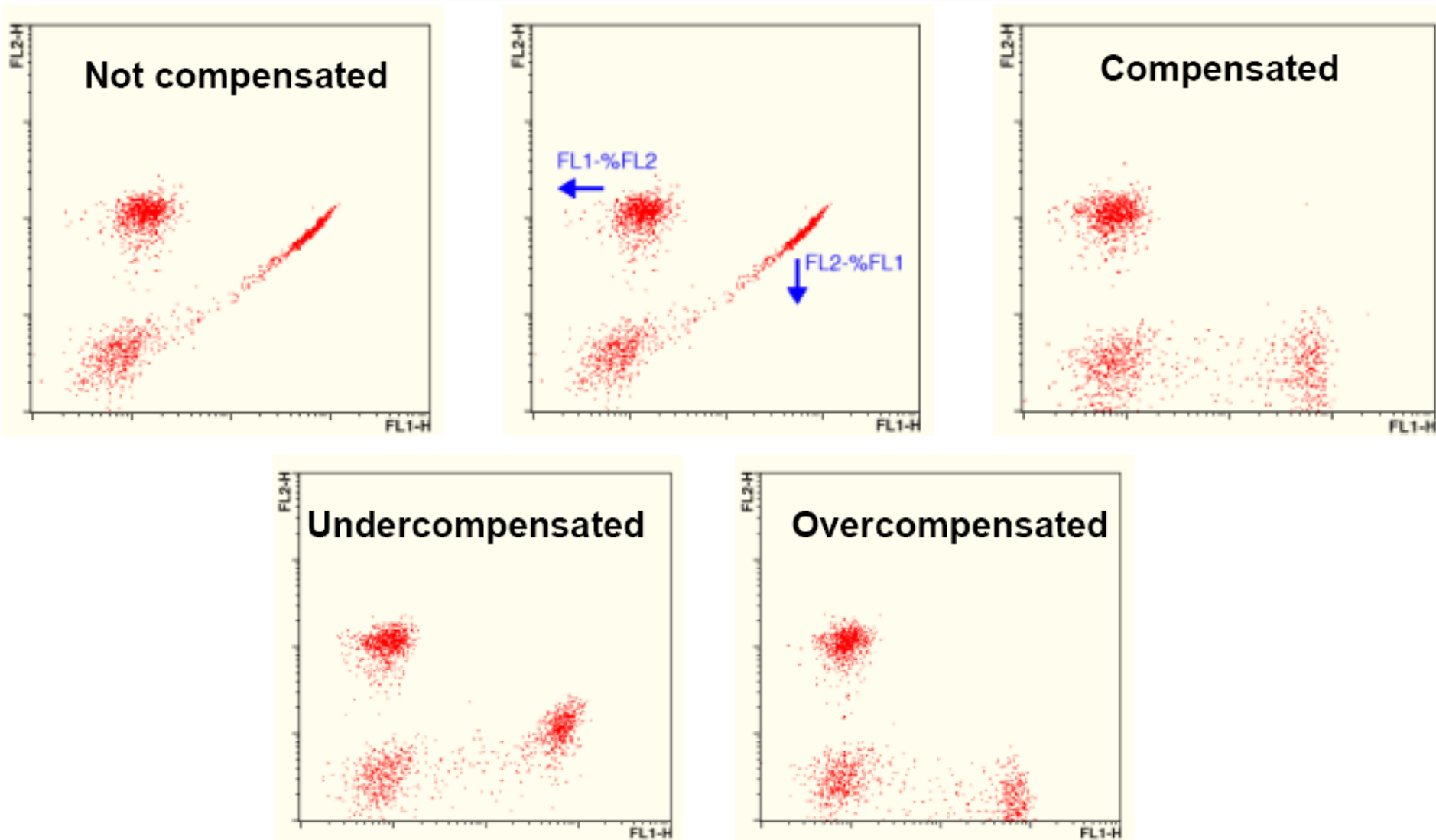

# How to Correct for Spectral Overlap between Fluorochromes?

uncompensate

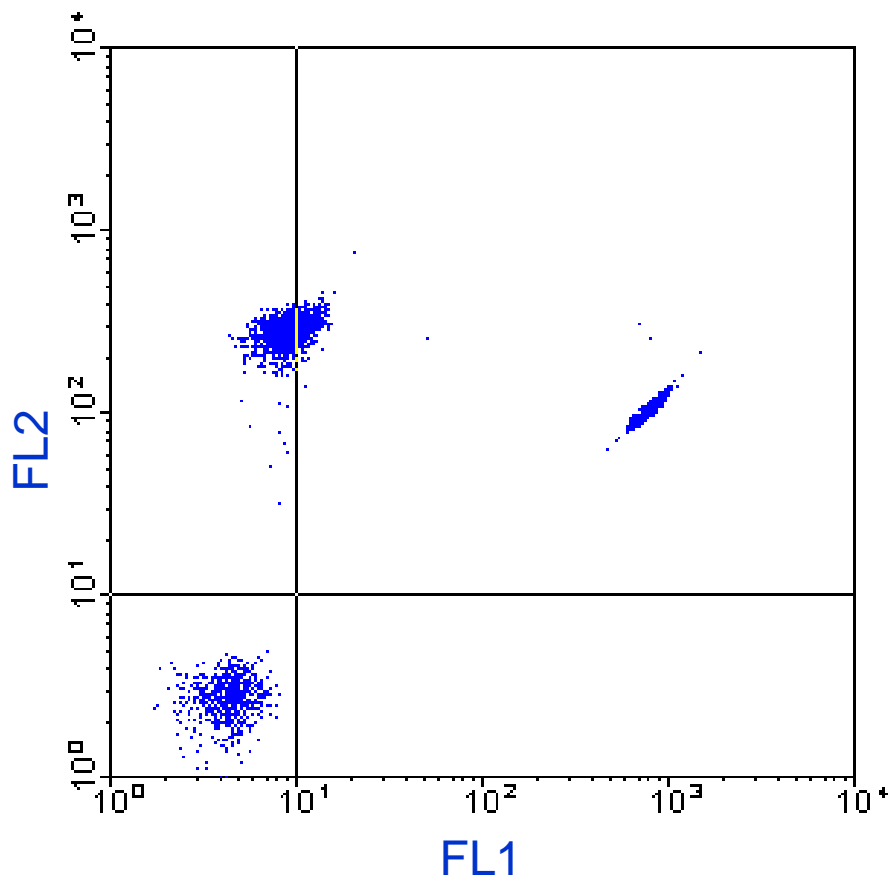

Under compensate

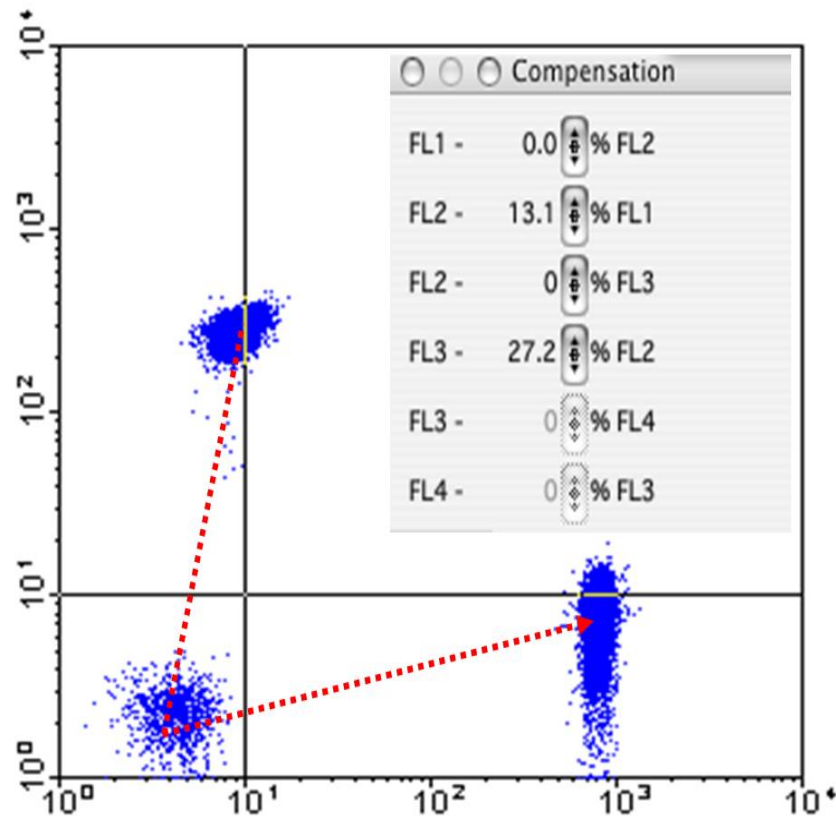

# How to Correct for Spectral Overlap between Fluorochromes?

compensate

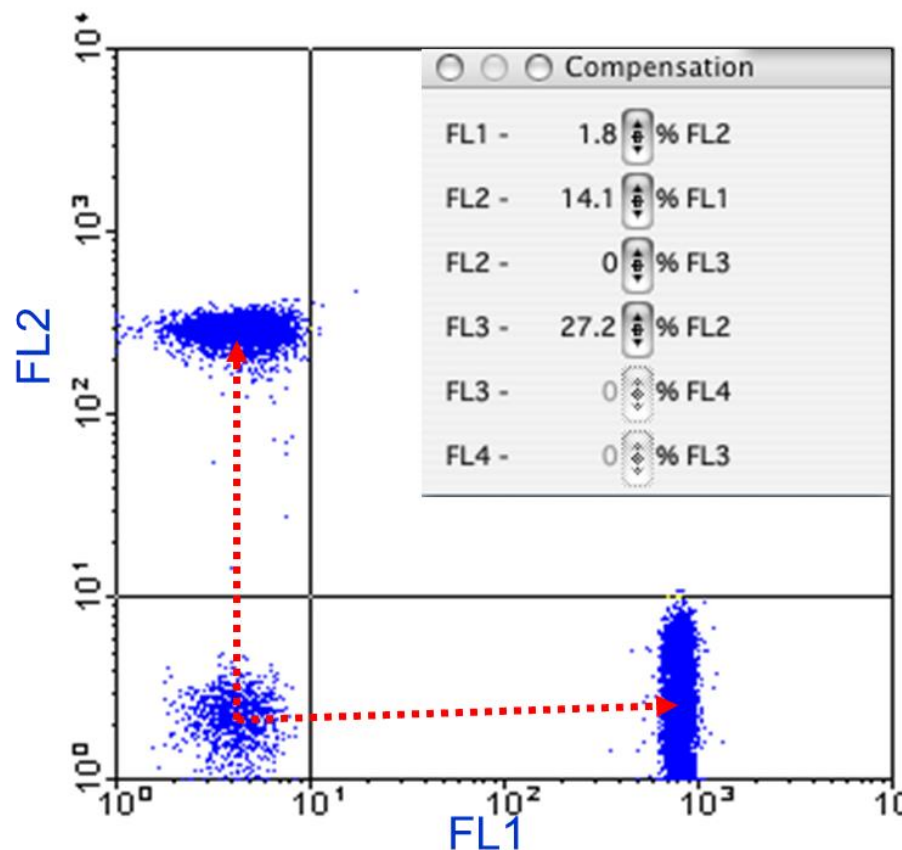

Over compensate

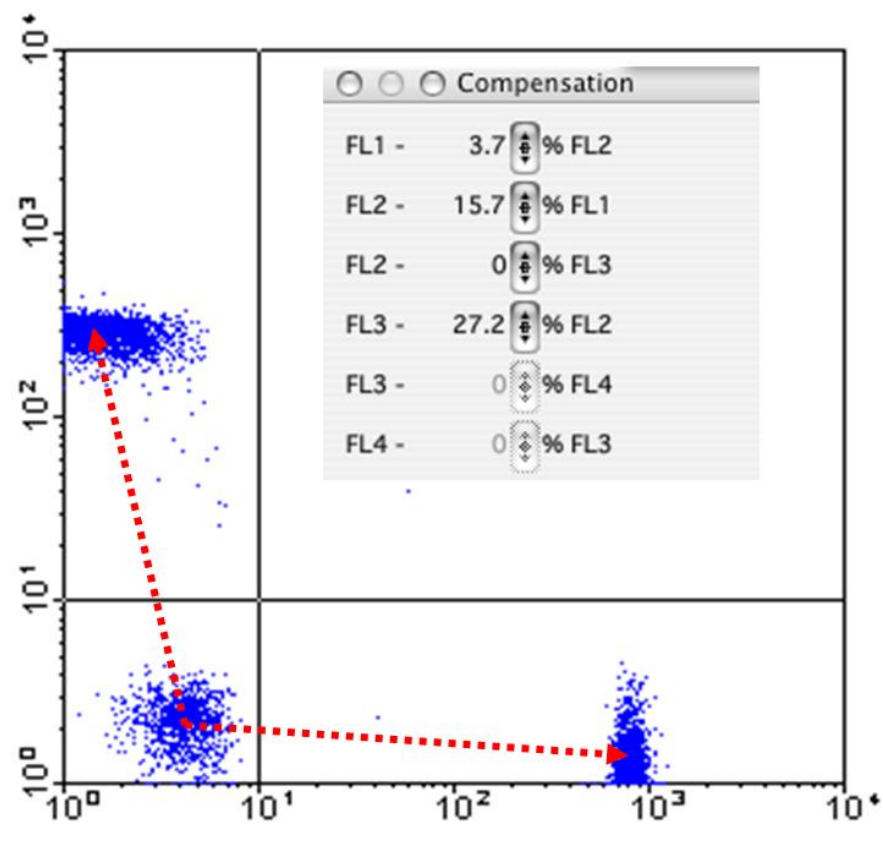

# How to Correct for Spectral Overlap between Fluorochromes?

## Compensation

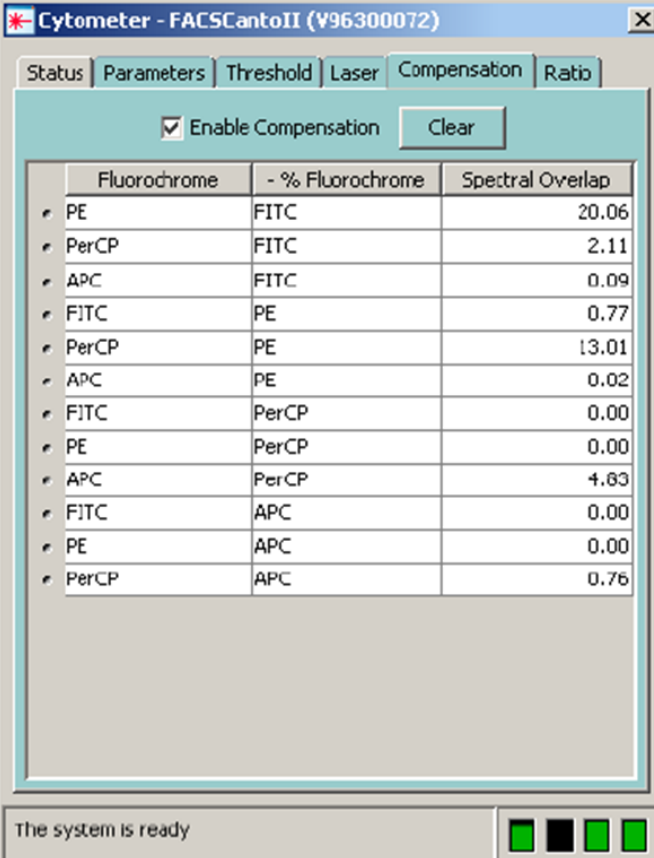

Cytometer - FACSCantoII (V96300072)

Status Parameters Threshold Laser Compensation Ratio

Enable Compensation Clear

Fluorochrome	- % Fluorochrome	Spectral Overlap
PE	FITC	20.06
PerCP	FITC	2.11
APC	FITC	0.09
FITC	PE	0.77
PerCP	PE	13.01
APC	PE	0.02
FITC	PerCP	0.00
PE	PerCP	0.00
APC	PerCP	4.63
FITC	APC	0.00
PE	APC	0.00
PerCP	APC	0.76

The system is ready

- Correction of spectral overlap
- depend on:
  - Fluorochromes used
  - Voltage settings
- Samples:
  - Unstained cells as negative control
  - Single stained samples for the calculation of the spectral overlap

# How to Correct for Spectral Overlap between Fluorochromes?

## Which tool for compensation?

### BD FACS™ 7- Color Setup Beads



### BD FACS™ CompBeads or CompBeads Plus



### Single stained cells



# How to Correct for Spectral Overlap between Fluorochromes?

## Tools for Compensation

### Antibody Capture Beads for Compensation

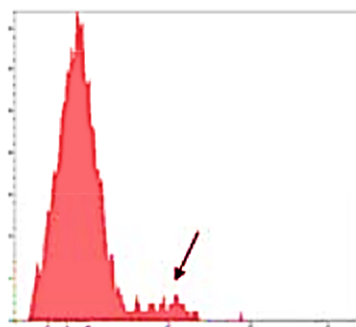

CD56-PE

Lymphocytes

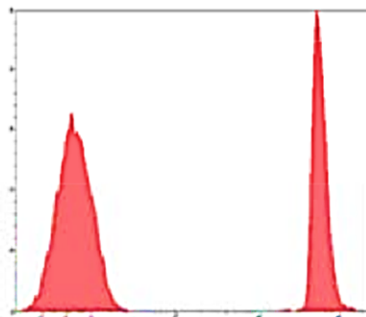

CD56-PE

AbC™ Compensation  
Beads

Lymphocytes  
Compensation set using  
antibody capture beads

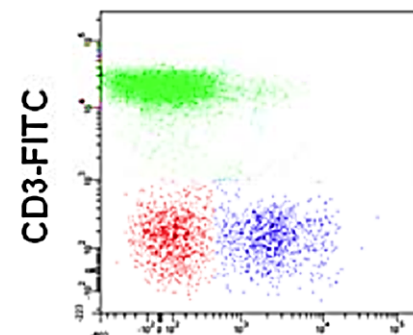

CD56-PE

- Useful when antigen expression is dim (as in CD56 example here)
- Useful when antigen expression is normally absent
- Useful when cell number is limited
- Uses same antibody conjugates as used in experiment

## Setting compensation- PMT Voltage

- Run unstained cells
- Adjust the PMT voltages so that the negative population is off the axis in every channel.

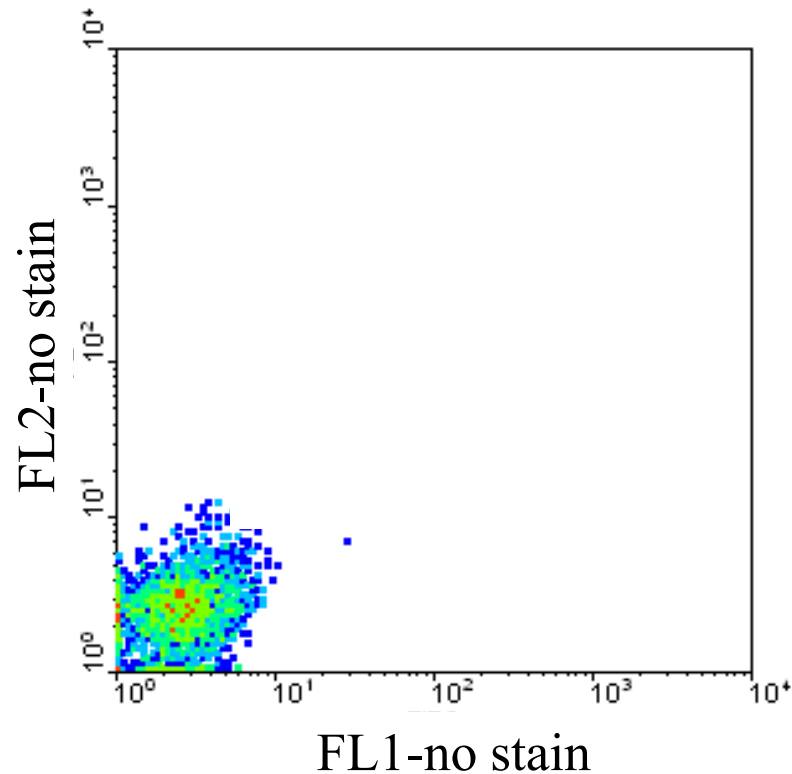

## Setting compensation - FITC single stain

- Run single stained control (FITC stained only)
- Adjust the compensation value so that positive and negative population have the same FL2 median fluorescence intensity.

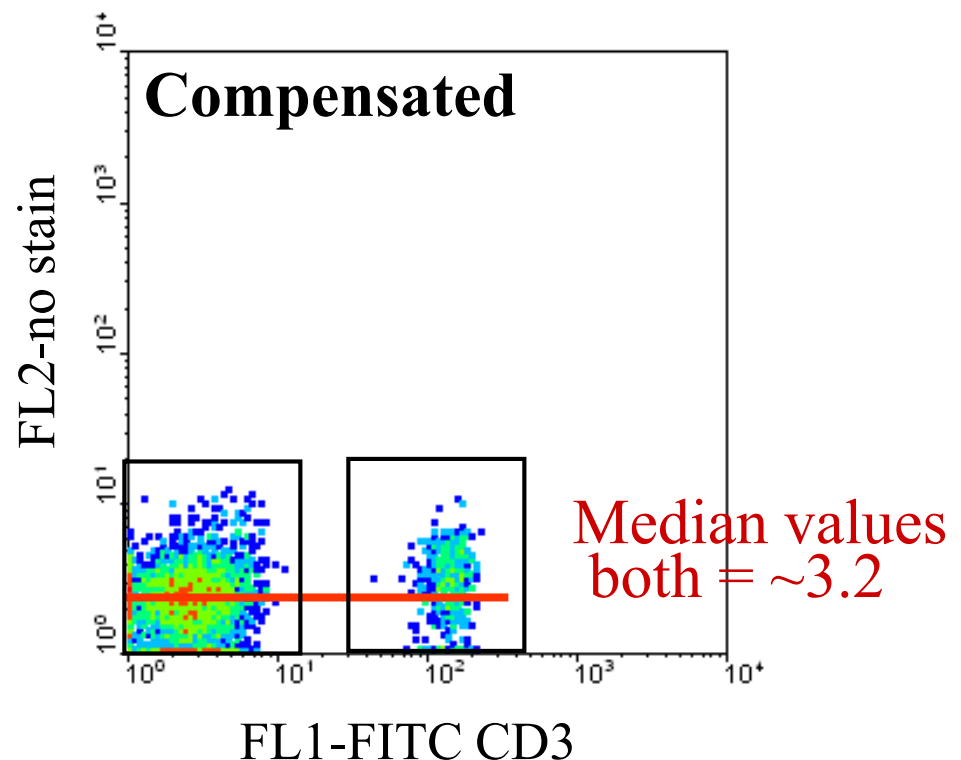
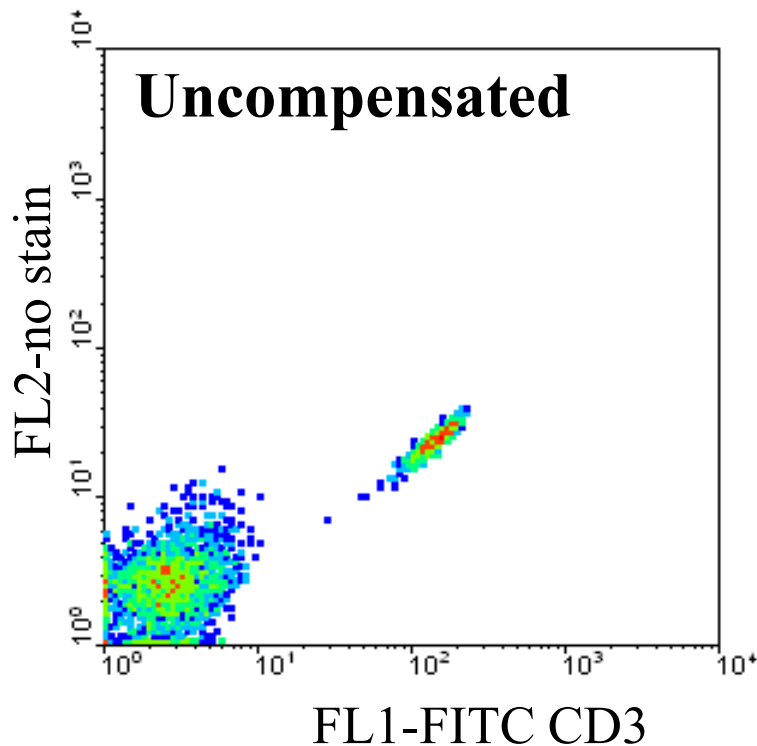

## Setting compensation - PE single stain

- Run single stained control (PE stained only)
- Adjust the compensation value so that positive and negative population have the same FL1 median fluorescence intensity.

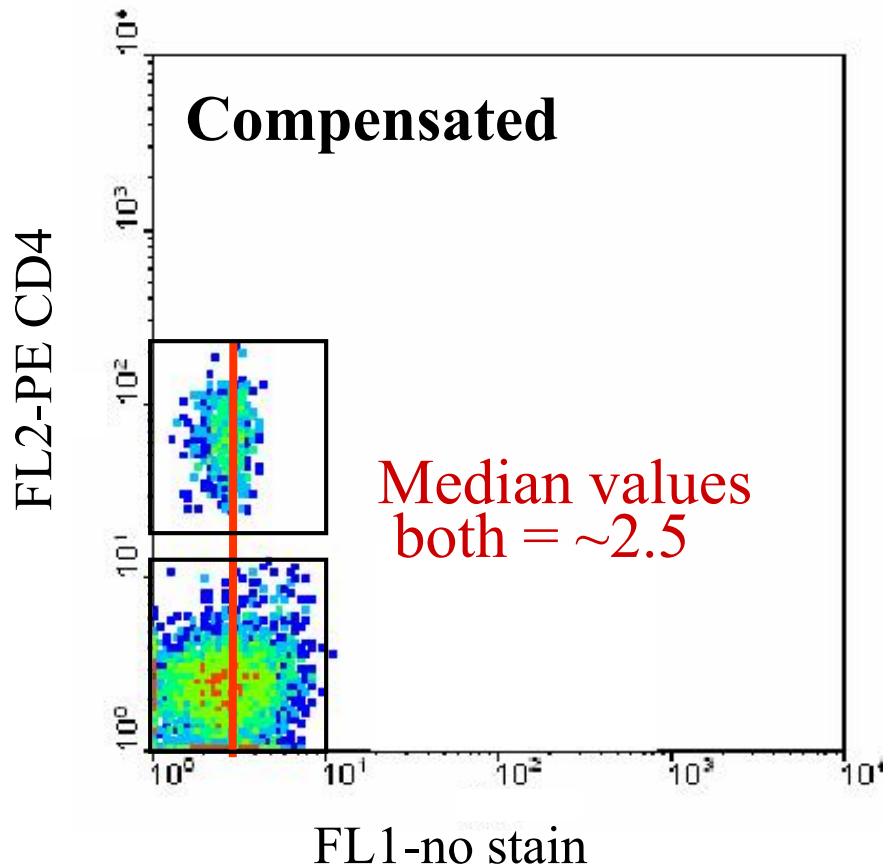

# How to Correct for Spectral Overlap between Fluorochromes?

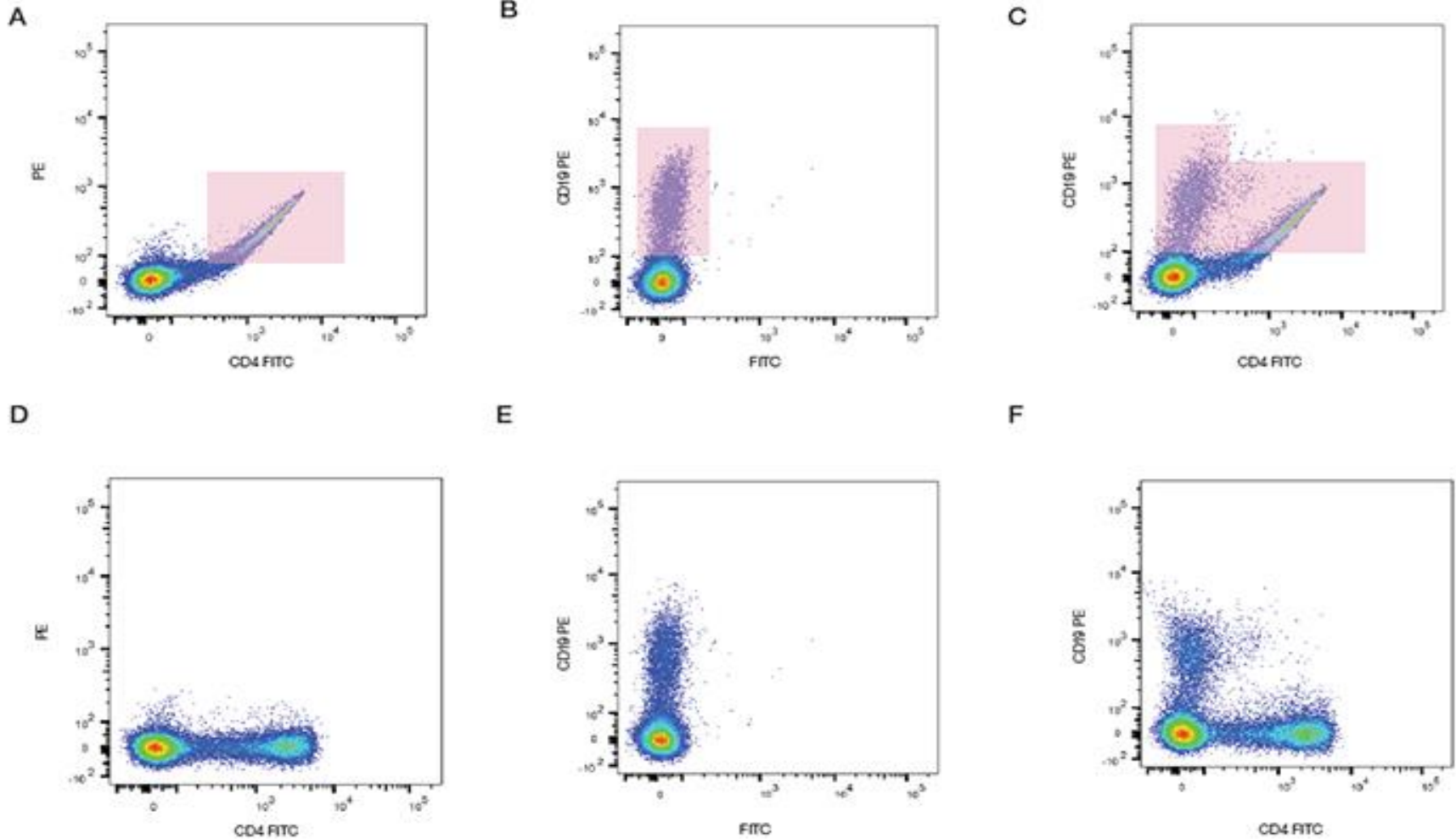

# How to Correct for Spectral Overlap between Fluorochromes?

## Examples

wrong compensation

ok

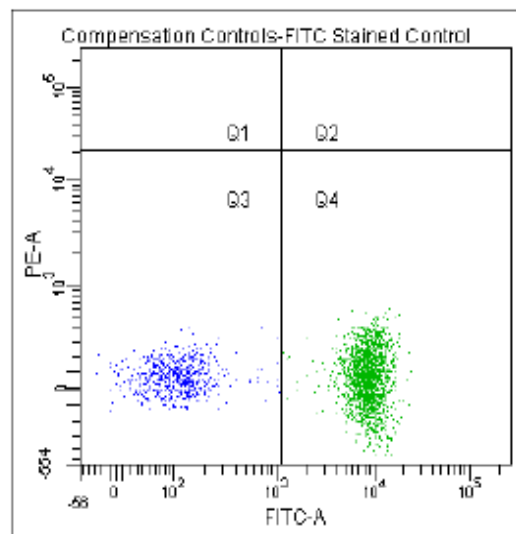

Specimen Name: Compensation Controls		Tube Name: FITC Stained Control	
Population		PE-A	Median
■ Q3			67
■ Q4			60

less

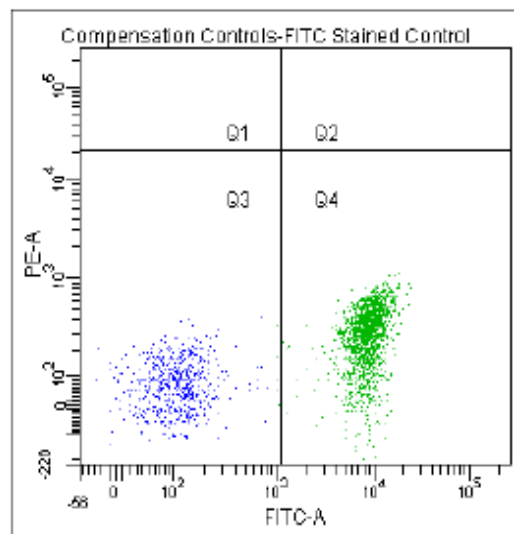

Specimen Name: Compensation Controls		Tube Name: FITC Stained Control	
Population		PE-A	Median
■ Q3			71
■ Q4			312

Too much

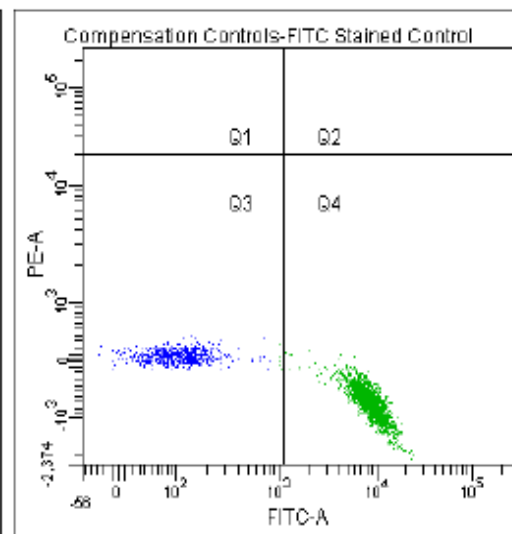

Specimen Name: Compensation Controls		Tube Name: FITC Stained Control	
Population		PE-A	Median
■ Q3			57
■ Q4			714

# How to Correct for Spectral Overlap between Fluorochromes?

## Which marker for compensation?

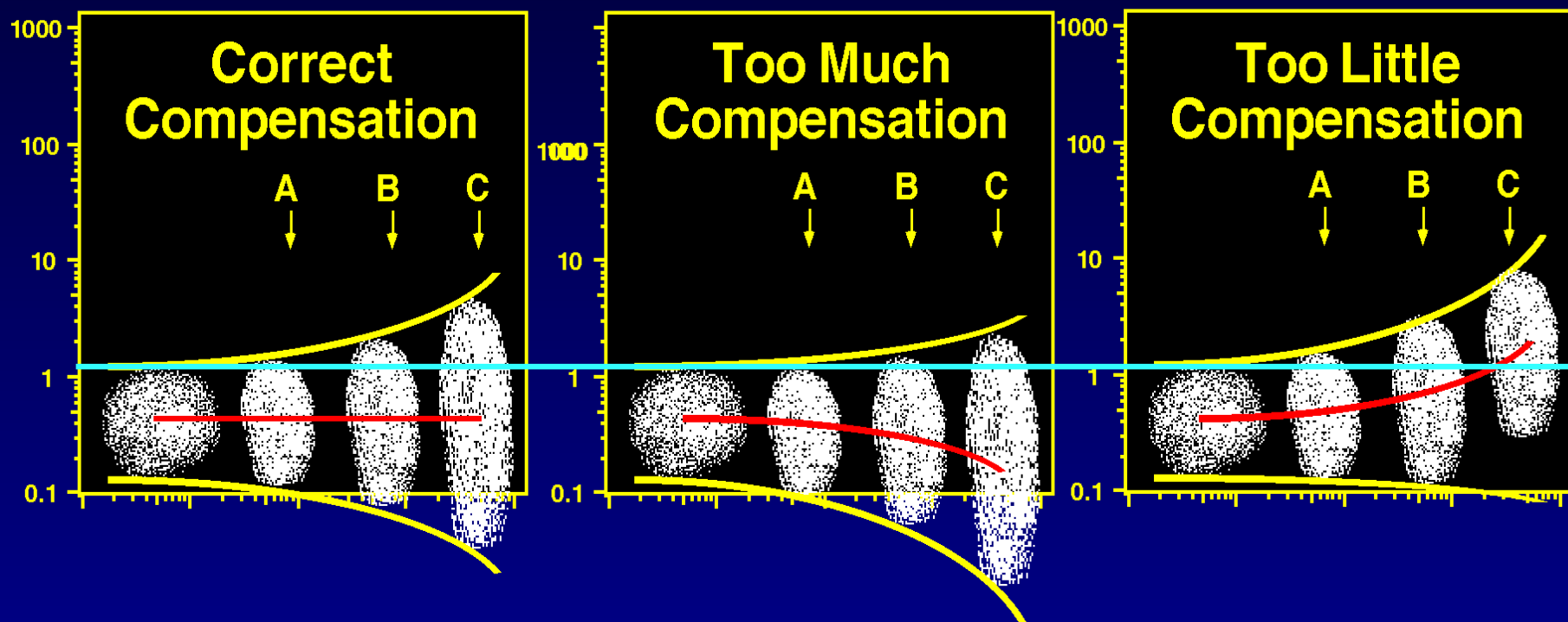

Small errors in compensation of a dim control (A) can result in large compensation errors with bright reagents (B & C). Use bright markers to setup proper compensation.

# Statistical data and Data Analysis Software

## ✓ **Online** Software:

- Acquisition and Analysis (both of them)
- Able to connect to the Cytometer
- Cell Quest Pro(BD), Flomax(Partec), FACS Diva(BD)

## ✓ **Offline** software:

- Just Data Analysis
- Flowjo, winMDI ,Cyflogic , Flowing software ,Cytobank

# Giving Statistical data and Data Analysis

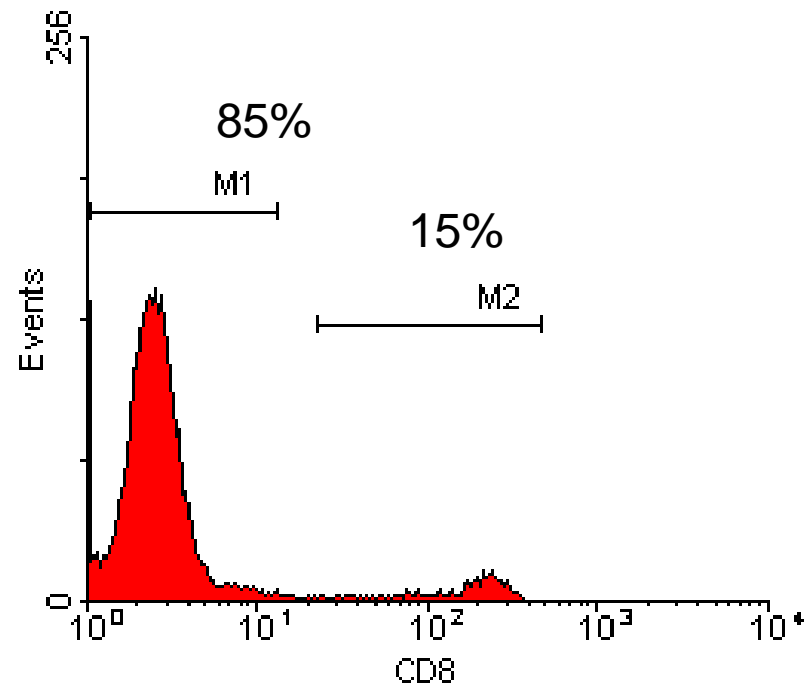
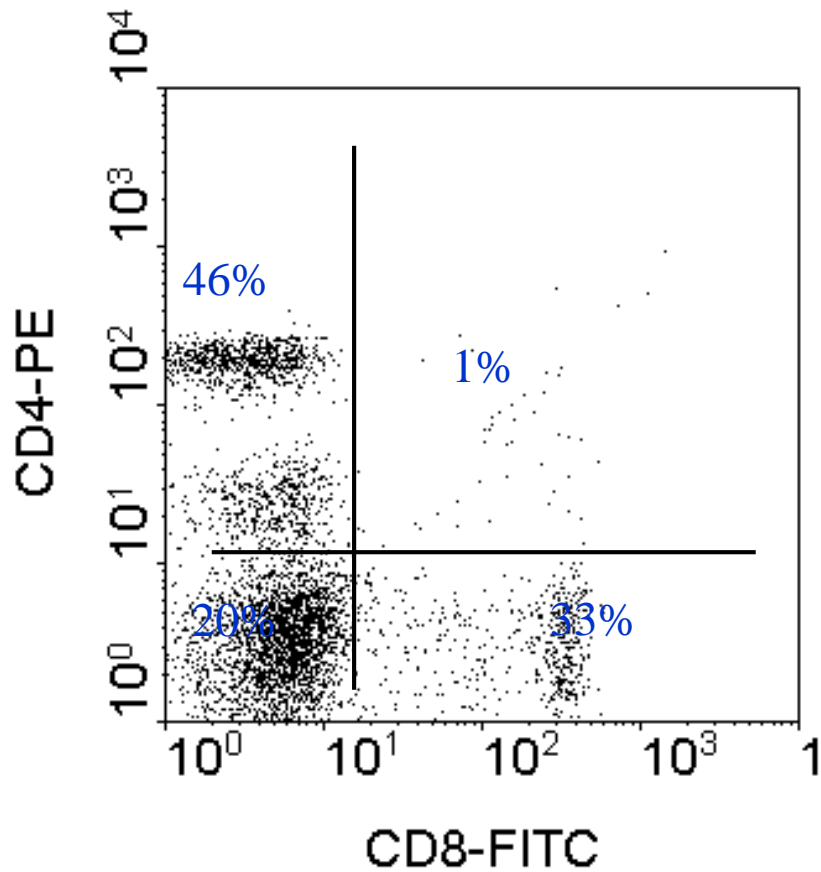

# Data Analysis-FlowJo Software





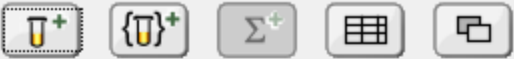









20231125 - FlowJo

File Edit Workspace Groups Tools Windows Help



Groups and Analyses

{ } All Samples

	Name	Statistic
<input type="checkbox"/> <input type="checkbox"/> <input type="checkbox"/>	 0.9-b.010	
<input type="checkbox"/> <input type="checkbox"/> <input type="checkbox"/>	 0.9-unstain.016	
<input type="checkbox"/> <input type="checkbox"/> <input type="checkbox"/>	 0.9-1.011	
<input type="checkbox"/> <input type="checkbox"/> <input type="checkbox"/>	 0.9-2.012	
<input type="checkbox"/> <input type="checkbox"/> <input type="checkbox"/>	 0.9-3.013	
<input type="checkbox"/> <input type="checkbox"/> <input type="checkbox"/>	 0.9-4.014	
<input type="checkbox"/> <input type="checkbox"/> <input type="checkbox"/>	 0.9-5.015	
<input type="checkbox"/> <input type="checkbox"/> <input type="checkbox"/>	 1.8-b.004	
<input type="checkbox"/> <input type="checkbox"/> <input type="checkbox"/>	 1.8-unstain.017	
<input type="checkbox"/> <input type="checkbox"/> <input type="checkbox"/>	 1.8-1.005	
<input type="checkbox"/> <input type="checkbox"/> <input type="checkbox"/>	 1.8-2.006	
<input type="checkbox"/> <input type="checkbox"/> <input type="checkbox"/>	 1.8-3.007	
<input type="checkbox"/> <input type="checkbox"/> <input type="checkbox"/>	 1.8-4.008	
<input type="checkbox"/> <input type="checkbox"/> <input type="checkbox"/>	 1.8-5.009	

# Data Analysis-FlowJo Software

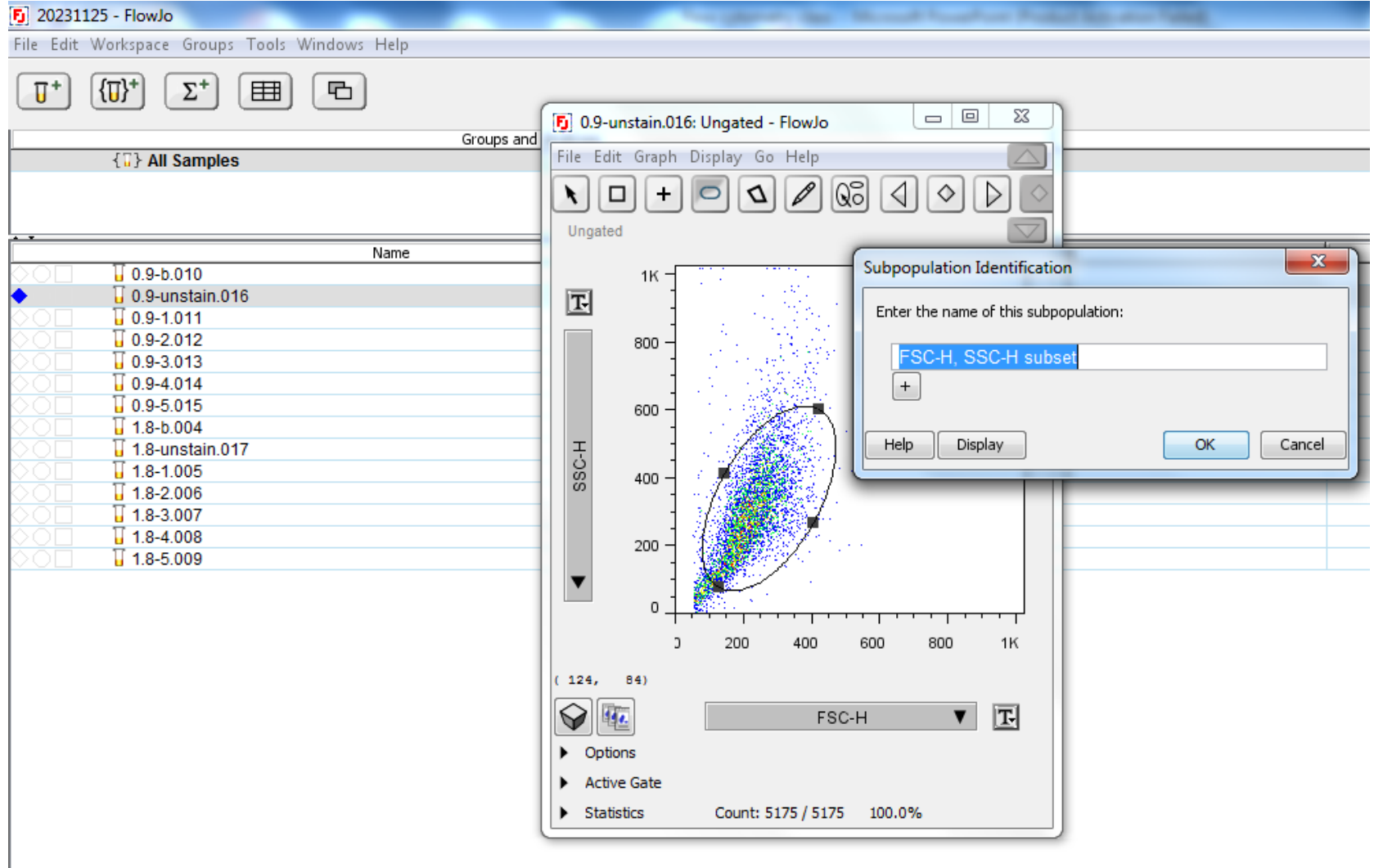

# Data Analysis-FlowJo Software

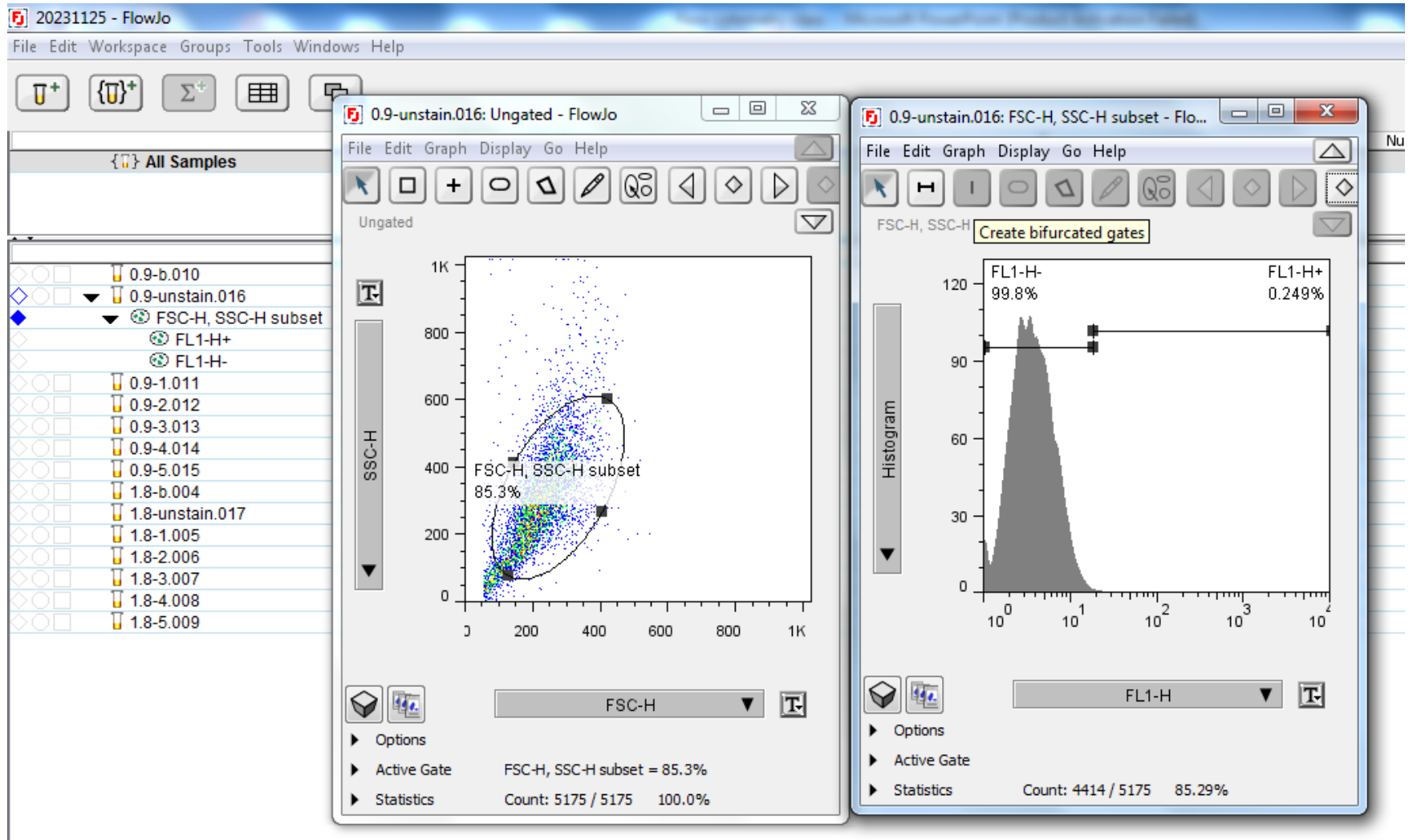

# Data Analysis-FlowJo Software

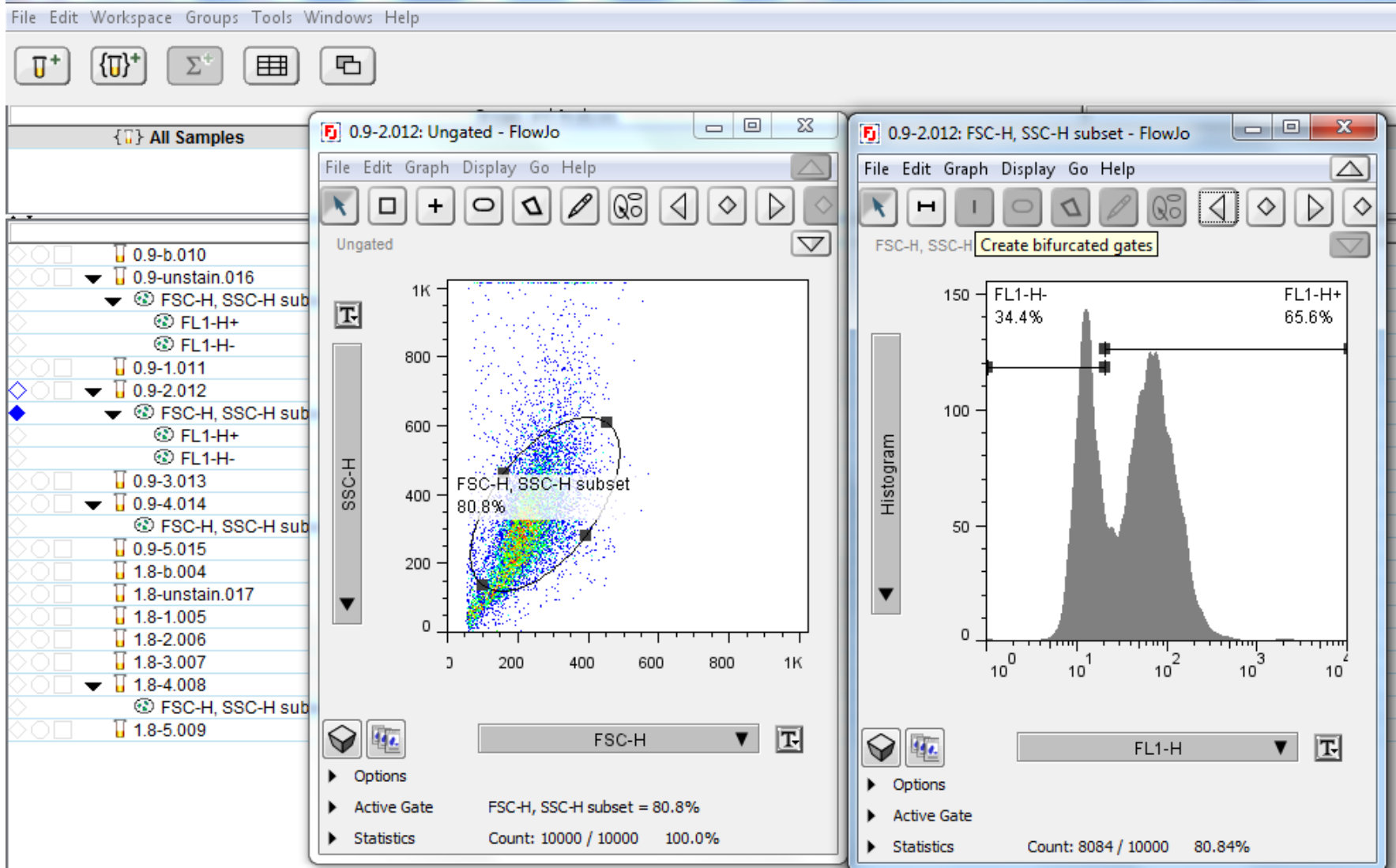

# Data Analysis-FlowJo Software

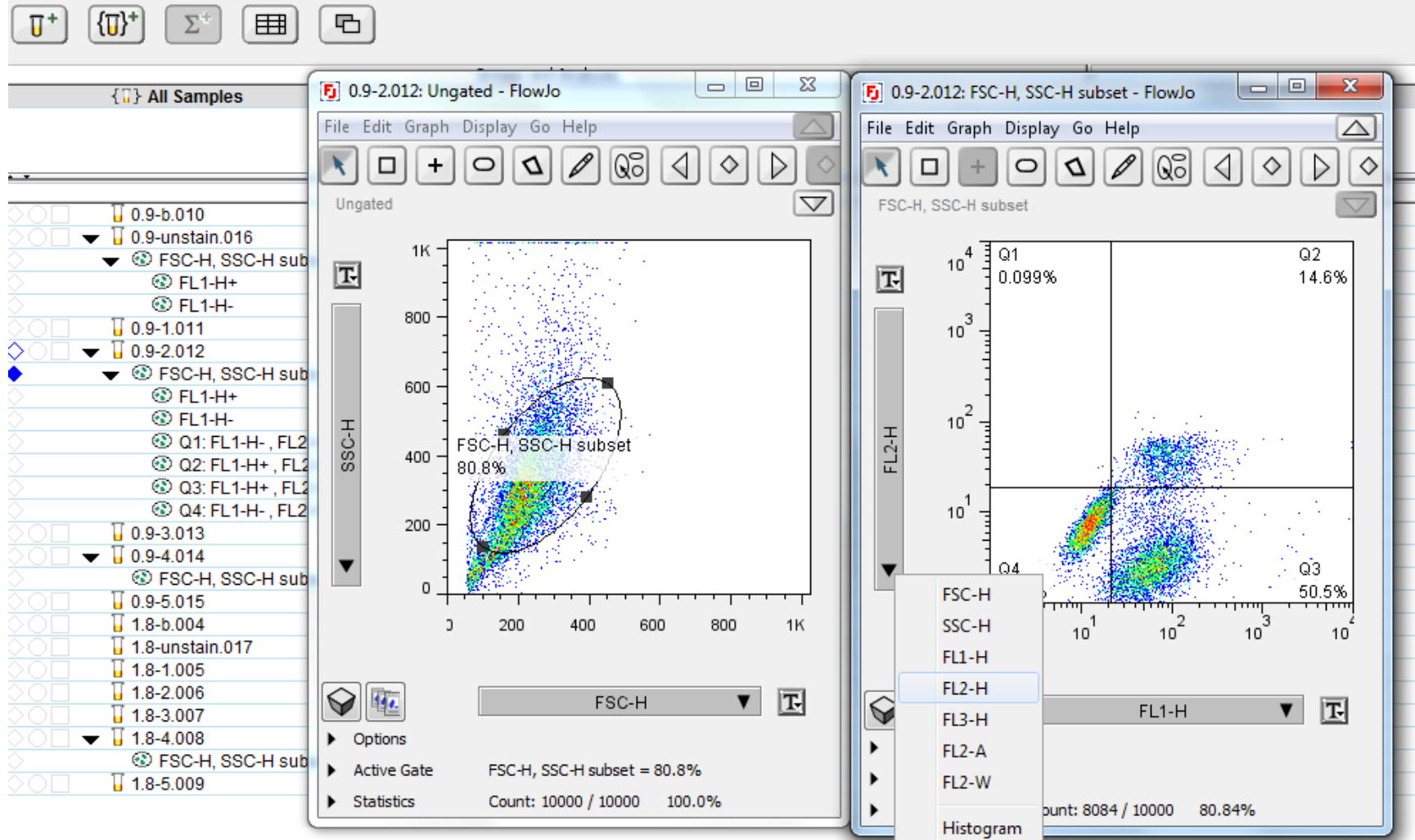

# Data Analysis-FlowJo Software

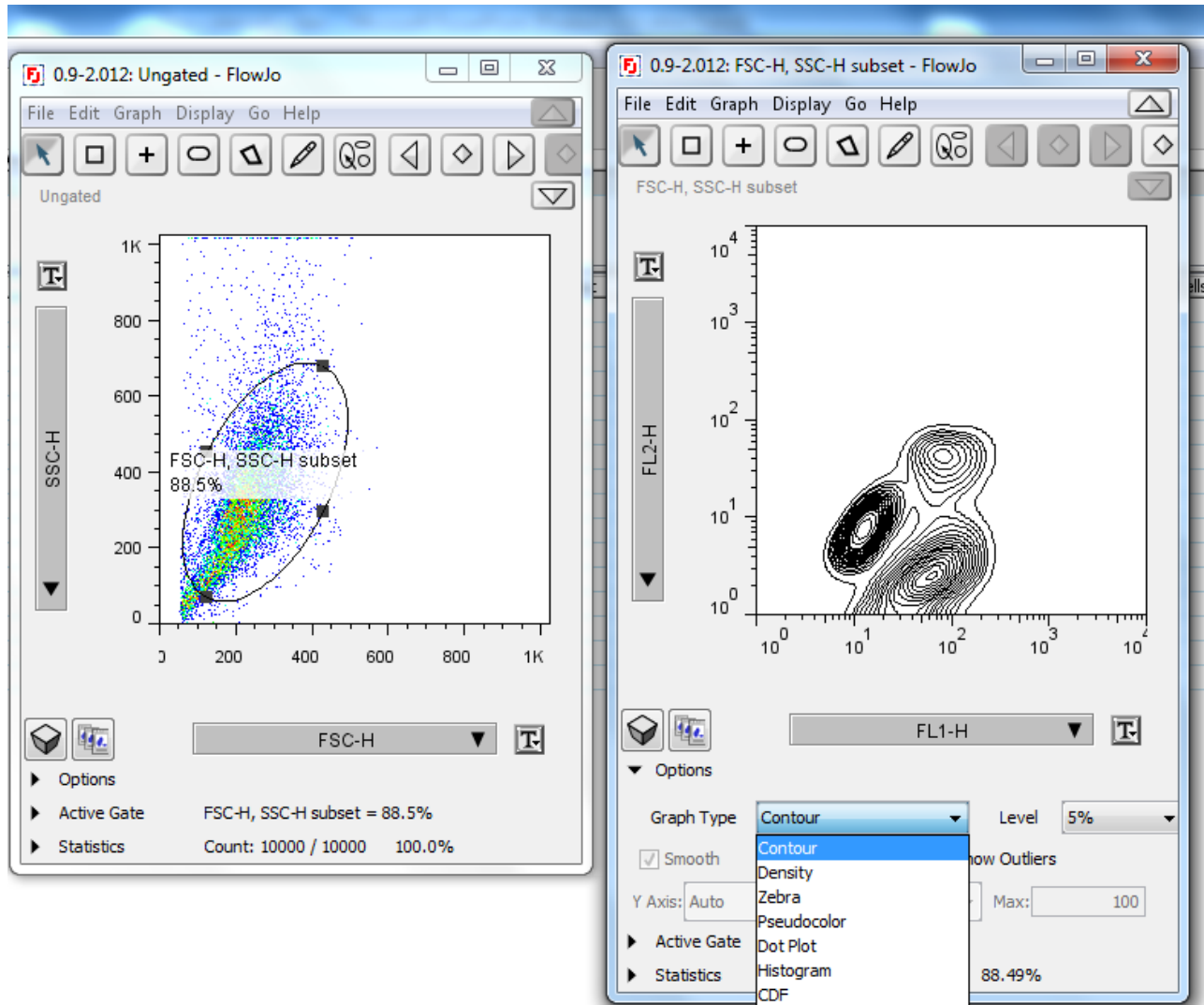

Any  
Question?





*Thanks for Attention*